

MOD[®] PLUS

Products
Catalogue

GENUINE SPARE PARTS



PLUS Means a step plus in quality



MOD®





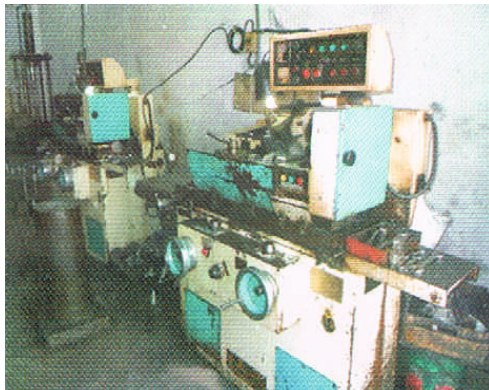



PLUS



S.NO.	TOPIC	PAGE NO.
01.	U.J. CROSSES (ALL MODEL)	1-6
02.	COMPLETE LONG FORK & SLEEVE BOTTLE SET.	7-10
03.	COMPLETE LONG FORK ASSEMBLED WITH DUST COVER	11-12
04.	REAR HOUSING / SLEEVE BOTTLE	13-16
05.	REAR HOUSING WITH WELCH PLUG	17
06.	YOKE & TEETH SET (TATA & LEYLAND, EICHER)	18-24
07.	SLEEVE YOKE (TATA & LEYLAND, EICHER)	25-28
08.	REAR TEETH (TATA & LEYLAND, EICHER)	29-36
09.	DUST COVER (RSB-325,403,490).....	37
10.	FRONT TEETH (ALL MODEL-LCV & HCV).....	38-40
11.	HALF YOKE (TATA & LEYLAND, EICHER).....	41-44
12.	CROSS HOLDER (TATA & LEYLAND, EICHER)	45-50
13.	COUPLING FLANGE (ALL MODEL LCV & HCV)	51-60
14.	YOKE & TEETH SET (MAHINDRA-JEEP, BOLERO, MAX PICKUP).....	61-62
15.	PRO. SHAFT-TATA ACE, MAHINDRA MAXIMO, L/L DOST	63
16.	STEERING CROSS ASSEMBLY (TATA & LEYLAND, BOLERO).....	64
17.	STG. CROSS ASSEMBLY WITH ROD & STG. WORMS-TATA ACE, MAGIC ...	65
18.	STEERING CROSS ASSEMBLY WITH ROD EICHER,LEYLAND	66
19.	STEERING SECTION & WORMS-TATA.....	67
20.	DIFF. SPIDER KIT (TATA ACE, MAGIC, ACE SUPER)	67
21.	STEERING SPINDLE (YOKE & TEETH) LCV & HCV	68-69
22.	CLUTCH FORK (LCV & HCV)	70
23.	GEAR HOUSING BLOCK ASSEMBLY.....	71
24.	CLUTCH SECTION (CLUTCH & COVER ASSEMBLY)	72







MOD[®] PLUS

U. J. CROSSES

Part No.	Products	Application	Cup Dia. (mm)	Cross Length (mm)
4009P		JEEP DIESEL, MARSHAL, COMMANDER UTILITI, PICKUP, BALERO, SCORPIO MAXXIMO, L/L DOST	27.00	81.80
4009GL		JEEP, BOLERO, SUMO SPICER, CRUISER O.E. TYPE GRESS LESS	27.00	81.80
4018P		AMBASSADAR L/L STG. CROSS ASSY.	23.85	61.20
4036P		TATA-407, TATA MOBILE 206, SIERRA, ESTATE, SUMO O/M	30.00	81.80
4036AP		SUMO SPICER, 207 DI CRUISER WITH CLAMP & BOLT	27.00	81.80
4050A		TATA ACE O/M (INNER LOCK)	23.80	35.25
4050B		TATA MAGIC N/M (OUTER LOCK)	22.00	55.00

MOD[®] PLUS

U. J. CROSSES







Part No.	Products	Application	Cup Dia. (mm)	Cross Length (mm)
4050BP		TATA ACE MEGA N/M HT (OUTER LOCK)	23.80	58.80
4050P		TATA 1210,608,609,807,407 N/M REAR	38.00	57.00
4050GL		TATA 1210,1109 GRESS LESS	38.00	57.00
4050I		TATA 1109(EX), TATA 407 PICK UP J.C.B. - 3DX	34.92	106.35
4050Z		MAHINDRA ZORAVATOR	35.00	94.00
4054P		TATA 1312, 1516, 1510, 1612 2213, 2416 (TURBO) 2515 TC (EX)	46.00	69.00
4054GL		TATA 1312, 1612 GRESS LESS	46.00	69.00

U. J. CROSSES

Part No.	Products	Application	Cup Dia. (mm)	Cross Length (mm)
4054AP		TATA-2515 EX CUP DIA 42.00MM TATA EURO-2, RSB 325	42.00	120.00
4054AP2		TATA-2515 EX CUP DIA 42.00MM TATA EURO-2, RSB 325 SMALL CUP (O.E. TYPE)	42.00	120.00
4054BP2		TATA-1613 TURBO, 2515 HYWA RSB TYPE, RSB 403 (SINGLE ROLLER)	42.00	129.00
4054CP		TATA-4018 CIRCLIP TYPE, TATA-3118, RSB-490 (SINGLE ROLLER)	48.00	135.00
4054EP		TATA 2515, 1623, AL 3518 SPR 2040	47.68	135.10
4054DP		TATA-4018 PATTI TYPE (SPICERS TYPE) AMW (TRUCK) MAHINDRA NAVISTAR	49.20	154.50
4081P		MATADOR/TRAX (OUTER LOCK)	30.00	81.80

MOD[®] PLUS

U. J. CROSSES



Part No.	Products	Application	Cup Dia. (mm)	Cross Length (mm)
4090P		BEDFORD J-4, LEYLAND 370, SHAKTIMAN N/M	39.68	115.40
4090QA		TOYOTA QUALIS/TAVERA O/M	29.00	47.30
4104A		TATA 1109/909 BS-III (SPICER TYPE)	34.92	126.00
4104P		LEYLAND TUSKER (MSL TYPE) LEYLAND-HINO, 1612 EICHER TRUCK 20.16 JUMBO	34.92	126.00
4104EP		LEYLAND TAURAS 2516, 3516 (CIRCLIP DESIGN)	47.64	135.00
4104GP		LEYLAND 2214, 3516, 2516, 3116, 1616 TATA 2515 TC (EX) REAR, TATA 2518 (EX) HYWA, EICHER GALAXY 3025 (SPICER TYPE)	41.28	126.00
4104GL		LEYLAND 2214, 3516, 2516, 3116, 1616 TATA 2515 TC (EX) REAR, TATA 2518 (EX) HYWA, EICHER GALAXY 3025 (SPICER TYPE)	41.28	126.00

U. J. CROSSES

Part No.	Products	Application	Cup Dia. (mm)	Cross Length (mm)
4108		TATA NOVUS (SPICER TYPE) 1810 SERIES	49.300	191.00
4113		AMW TRUCK 4923/4930	57.00	144.00
4113A		TATA 4923, 57MM x 152MM SPR 2055, RSB 620	57.00	152.00
4122		AMW TRUCK	52.00	133.00
4122A		TATA-4928-S-PRIMA, VOLVO-SM-7 SM9 & VOLVO 400 SPR 2045, RSB 590	52.00	147.00
4131P		CANTER N/M, SWARAJ MAZDA, CANTER 10.75, 11.10, 10.90, 11.90, L/L COMET JUNIOR L/L IVECO (CARGO) 709, 909 TATA 407 TURBO REAR, CAB KING MAHINDRA	30.20	106.30
4132P		EICHER CANTER N/M, SWARAJ MAZDA TATA LPT/SFC 909/709 EX/407EX/LPK TIPPER/ A-L CARGO - 709/909 WITH LONG BEARING CUP	30.20	106.30

MOD[®] PLUS









U. J. CROSSES

Part No.	Products	Application	Cup Dia. (mm)	Cross Length (mm)
4153P		TATA 407 TURBO FRONT CHEVEROLET/ALLWYN NISSAN XYLO, SCORPIO N/M	30.00	92.00
4203AP		MARUTI VAN (INNER LOCK)	25.00	40.50

COMPLETE LONG FORK & SLEEVE BOTTLE SET

Part No.	Products	Application	UJ Cross (BxG)	Cross Ref.	No. of Splines	Pipe Dia	Mating Part Long Fork	Mating Part R. Housing
I5362G-3		COMPLETE TATA 2515 EX RSB-325 SERIES SET WITH DUST COVER LENGTH-12.5"	RSB 325 42 x 120	4054AP 4054AP2	20	3.5"	I5342	I5342C
I5362-I		COMPLETE RSB-325 SERIES SET WITH DUST COVER COATED LENGTH-12.5"	RSB 325 42 x 120	4054AP 4054AP2	20	3.5"	I5342	I5342CT
I5340B-2		COMPLETE RSB-325 SERIES SET WITH DUST COVERS LENGTH-12.5"	RSB 325 42 x 120	4054AP 4054AP2	20	4"	I5342	I5342D
I5340BT		COMPLETE RSB-325 SERIES SET WITH DUST COVER LENGTH-12.5" COATED	RSB 325 42 x 120	4054AP 4054AP2	20	4"	I5342	I5342DT
I5362F		COMPLETE RSB-403 SERIES SET WITH DUST COVER LENGTH - 13"	RSB 403 42 x 129	4054BP2	20	3.5"	I5342-A	I5342C
I5362FT		COMPLETE RSB-403 SERIES SET WITH DUST COVER LENGTH - 13" COATED	RSB 403 42 x 129	4054BP2	20	3.5"	I5342-A	I5342CT
I5362G		COMPLETE RSB-403 SERIES SET WITH DUST COVER LENGTH - 13"	RSB 403 42 x 129	4054BP2	20	4.0"	I5342-A	I5342D
I5362GT		COMPLETE RSB-403 SERIES SET WITH DUST COVER COATED LENGTH - 13"	RSB 403 42 x 129	4054BP2	20	4.0"	I5342-A	I5342DT
I5362G-2		COMPLETE RSB-403 LONG SET WITH DUST COVER TATA 2518 LENGTH - 14.5"	RSB 403 42 x 129	4054BP2	20	4.0"	I5342B	I5342F
I5362J		COMPLETE RSB-403 SERIES LONG SET WITH DUST COVER TATA 2518 COATED LENGTH - 14.5"	RSB 403 42 x 129	4054BP2	20	4.0"	I5342B	I5342FT



COMPLETE LONG FORK & SLEEVE BOTTLE SET

Part No.	Products	Application	UJ Cross (BxG)	Cross Ref.	No. of Splines	Pipe Dia	Mating Part Long Fork	Mating Part R. Housing
I5362GP		COMPLETE RSB-403 LONG SET WITH DUST COVER TATA 2518 LENGTH - 16"	RSB 403 42 x 129	4054BP2	20	4.0"	I5342BP	I5342E
I5362GPT		COMPLETE RSB-403 LONG SET WITH DUST COVER TATA 2518 COATED LENGTH - 16"	RSB 403 42 x 129	4054BP2	20	4.0"	I5342BP	I5342ET
I5718B		COMPLETE RSB-490 SET WITH DUST COVER TATA 4018 LENGHT 13"	RSB 490 48 x 135	4054CP	30	4.0"	I5718B1	I5718B2
I5718BT		COMPLETE RSB-490 SET WITH DUST COVER TATA 4018 COATED LENGTH-13"	RSB 490 48 x 135	4054CP	30	4.0"	I5718B1	I5718CT
I5718E		COMPLETE RSB-490 LONG SET WITH DUST COVER TATA 4018 LONG LENGTH-14.5"	RSB 490 48 x 135	4054CP	30	4.0"	I5720A	I5720
I5718D		COMPLETE RSB-490 LONG SET WITH DUST COVER TATA 4018 LONG COATED LENGTH-14.5"	RSB 490 48 x 135	4054CP	30	4.0"	I5720A	I5718C
I5718G		COMPLETE RSB 490 EXTRA LONG LENGTH - 16"	RSB 490 48 x 135	4054CP	30	4.0"	I5720C	I5720BP
I5718GP		COMPLETE RSB-490 EXTRA LONG SET WITH DUST COVER TATA 4018 LENGTH-16" COATED	RSB 490 48 x 135	4054CP	30	4.0"	I5720C	I5720B
I5718H		COMPLETE SPICER 2040 (I&S) SERIES SET WITH DUST COVER	SPR 2040 47.68 x 135.10	4054EP	34	4.0"		
I5718HP		COMPLETE SPICER 2040 (I&S) SERIES SET WITH DUST COVER COATED	SPR 2040 47.68 x 135.10	4054EP	34	4.0"	I5718H2	I5718H1

COMPLETE LONG FORK & SLEEVE BOTTLE SET

Part No.	Products	Application	UJ Cross (BxG)	Cross Ref.	No. of Splines	Pipe Dia	Mating Part Long Fork	Mating Part R. Housing
N/A		COMPLETE SPICER 2040 SERIES SET WITH DUST COVER	SPR 2040 47.68 x 135.10	4054EP	34	4.5"		
N/A		COMPLETE SPICER 2040 SERIES SET WITH DUST COVER COATED	SPR 2040 47.68 x 135.10	4054EP	34	4.5"		
N/A		COMPLETE RSB 590 SERIES WITH DUST COVER	RSB 590 52 x 147	4122A	36	4.5"		
15930C		COMPLETE RSB 590 SERIES WITH DUST COVER COATED	RSB 590 52 x 147	4122A	36	4.5"		
N/A		COMPLETE SPICER 2045 SERIES SET WITH DUST COVER	SPICER 2045 52 x 147.2	4122-A	38	4.5"		
N/A		COMPLETE SPICER 2045 SERIES SET WITH DUST COVER COATED	SPICER 2045 52 x 147.2	4122-A	38	4.5"		
N/A		COMPLETE SPICER 2047 SERIES SET WITH DUST COVER	SPICER 2045 52 x 147.2	4122-A	38	4.5"		
N/A		COMPLETE SPICER 2047 SERIES SET WITH DUST COVER COATED	SPICER 2047 52 x 147.2	4122-A	38	4.5"		
N/A		COMPLETE RSB 620 SERIES WITH DUST COVER	RSB 620 57 x 152	4113A	36	4.5"		
N/A		COMPLETE RSB 620 SERIES WITH DUST COVER COATED	RSB 620 57 x 152	4113A	36	4.5"		

COMPLETE LONG FORK & SLEEVE BOTTLE SET

Part No.	Products	Application	UJ Cross (BxG)	Cross Ref.	No. of Splines	Pipe Dia	Mating Part Long Fork	Mating Part R. Housing
N/A		COMPLETE SPICER 2055 SERIES SET WITH DUST COVER	SPICER 2055 57 x 152	4113A	38	4.5"		
N/A		COMPLETE SPICER 2055 SERIES SET WITH DUST COVER COATED	SPICER 2055 57 x 152	4113A	38	4.5"		
N/A		COMPLETE SPICER 2060 SERIES SET WITH DUST COVER	SPICER 2060 59 x 167.7	N/A	40	4.5"		
N/A		COMPLETE SPICER 2060 SERIES SET WITH DUST COVER COATED	SPICER 2060 59 x 167.7	N/A	40	4.5"		
N/A		COMPLETE SPICER SPL 90, L/L 2516	SPICER SPL 90 41.28 x 126	4104GP	20	4"		
N/A		COMPLETE SPICER SPL 90, L/L 2516 COATED	SPICER SPL 90 41.28 x 126	4104GP	20	4"		
N/A								
N/A								
N/A								
N/A								

COMPLETE LONG FORK ASSEMBLED WITH DUST COVER

Part No.	Products	Application	UJ Cross (BxG)	Cross Ref.	No. of Splines	Length	Mating Housing
I5342		LONG FORK RSB 325 SERIES TATA 2515 EX, 1613 TURBO	RSB 325 42 x 120	4054AP 4054AP2	20	12.5"	I5342C
I5342A		RSB 403 SERIES LONG FORK WITH DUST COVER TATA 2515 (SMALL)	RSB 403 42 x 129	4054BP2	20	13"	I5342D
I5342B		RSB 403 SERIES LONG FORK WITH DUST COVER TATA 2518 (MEDIUM)	RSB 403 42 x 129	4054BP2	20	14.5"	I5342F
I5342BP		RSB 403 SERIES LONG FORK WITH DUST COVER TATA 2518 (LONG)	RSB 403 42 x 129	4054BP2	20	15.5"	I5342E
I5718B-1		RSB 490 SERIES LONG FORK WITH DUST COVER TATA 4018	RSB 490 48 x 135	4054CP	30	13"	I5718B2
I5720A		RSB 490 SERIES LONG FORK WITH DUST COVER TATA 4018/3118 LONG	RSB 490 48 x 135	4054CP	30	14.5"	I5720
I5720C		RSB 490 SERIES LONG FORK WITH DUST COVER TATA 4018/ EXTRA LONG	RSB 490 48 x 135	4054CP	30	16"	I5720BP
N/A		TATA LPS-4021 LEYLAND ULE-390	SPR 2040 47.68 x 135.10	4054EP	34	10.25"	
I5718H-2		LONG FORK TATA LPS 4928 LPT-3138, LPK-2518 L/L-3119N BHARAT BENZ2523C 2528C,3128C,4928TT	SPR 2040 47.68 x 135.10	4054EP	34	15"	
N/A		TATA 2518/4018/3118	RSB 590 52 x 147	4122A	36	14.5"	

COMPLETE LONG FORK ASSEMBLED WITH DUST COVER

Part No.	Products	Application	UJ Cross (BxG)	Cross Ref.	No. of Splines	Pipe Dia	Mating Part Long Fork	Mating Part R. Housing
N/A		TATA LPTA 1628 LPO 2138, L/L HMV 6X6 SHA-8T, MERITOR AXLE, EICHER TIPPER 25T 259HP, MAN LPTA 1828 6X6	SPICER 2047 52 x 147	4122A	38	10.65"		
N/A		TATA LPS 4028 LPK 3128, L/L-3123 BHARAT BENZ 2523C 4023TT, EICHER TERRA-25T MAN CLA-18.28	SPICER 2047 52 x 147	4122A	38	13.75"		
N/A		TATA 2515/4018 LONG 3118	RSB 620 57 x 152	4113A	36	14.5"		
N/A		TATA LPTA-1628 2038-L/L 4936 BHARAT BENZ LPTA-1628, LPTA 2038	SPICER 2055 57 x 152	4113A	38	14"		
N/A		TATA LPTA-3138 L/L-FV-2636 EICHER 40T TIPPER MAN 31.28	SPICER 2060 59 x 167.7	N/A	40	14"		
N/A		COMPLETE SPICER SPL 90, L/L 2516 COATED	SPR 403 42 x 129	4054BP2	20	16"		

REAR HOUSING/SLEEVE BOTTLE

Part No.	Products	Application	Pipe Fitting Size	No. of Splines	Mating Long Fork	Total Length (L)	O.E.M Ref.
I5342C		RSB 325 SERIES, TATA 2515 EX, 1613 TURBO	3.5"	20	I5342	6.50"	F540 325 084 180, 2632 4112 5109
						171mm	
I5342CT		RSB 325 SERIES, 1613 TURBO TEFLONE COATED	3.5"	20	I5342	6.50"	F540 325 084 180, 2632 4112 5109
						171mm	
N/A		RSB 325 SERIES, TATA 2515 EX, 1613 TURBO	3.5"	20		9.0"	TATA LPO 1512
						224mm	
N/A		RSB 325 SERIES, TATA 2515 EX, 1613 TURBO COATED	3.5"	20		9.0"	TATA LPO 1512
						224mm	
I5342D		RSB 403 SERIES SHORT TATA 2518	4"	20	I5342A	7.0"	F541 325 094 180, 21714112 5106
						171mm	
I5342DT		RSB 403 SERIES SHORT TATA 2518 COATED	4"	20	I5342A	7.0"	F541 325 094 180, 21714112 5106
						171mm	
I5342F		RSB 403 SERIES LONG MEDIUM	4"	20	I5342B	9.0"	F556 325 064 220
						224mm	
I5342FT		RSB 403 SERIES LONG MEDIUM COATED	4"	20	I5342B	9.0"	F556 325 064 220
						224mm	
I5342E		RSB 403 SERIES, TATA 2518 LONG	4"	20	I5342BP	10.5"	F556 325 064 220 2167 4112 5108
						263mm	
I5342ET		RSB 403 SERIES, TATA 2518 EXTRA LONG COATED	4"	20	I5342BP	10.5"	F556 325 064 220 2167 4112 5108
						263mm	

REAR HOUSING/SLEEVE BOTTLE

Part No.	Products	Application	Pipe Fitting Size	No. of Splines	Mating Long Fork	Total Length (L)	O.E.M Ref.
I5718B2		RSB 490 SERIES, TATA 4018	4"	30	I5718B1	7.75"	F540 490 095 268, 2167 4112 5104
						196mm	
I5718CT		RSB 490 SERIES, TATA 4018 COATED	4"	30	I5718B1	7.75"	F540 490 095 268, 2167 4112 5104
						196mm	
I5720		RSB 490 SERIES, LONG TATA 4018/3118	4"	30	I5720A	9.0"	F550490062373
						225mm	
I5718C		RSB 490 SERIES, LONG TATA 4018/3118 COATED	4"	30	I5720A	9.0"	F550490062373
						225mm	
I5720BP		RSB 490 SERIES, LONG, TATA 4018/3118 LENGTH - 16"	4"	30	I5720C	10.0"	F550 490 062 373
						257mm	
I5720B		RSB 490 SERIES, LONG, TATA 4018/3118 TEFLONE COATED LENGTH - 16"	4"	30	I5720C	10.0"	F550 490 062 373
						257mm	
N/A		TATA LPS 4928 LPTA 3138, LPK 2528, L/L3119N, BHARAT BENZ 2523C 2528C, 3128C, 4928TT	4"	34		9.5"	
						240mm	
N/A		TATA LPS 4928, LPTA 3138, LPK 2528, L/L 3119N, BHARAT BENZ 2523C, 2528C, 3128C, 4928TT COATED	4"	34		9.5"	
						240mm	
N/A		TATA LPS 4928 LPTA 3138, LPK 2528, L/L3119N, BHARAT BENZ 2523C 2528C, 3128C, 4928TT	4"	34		10.5"	6687407780 2130348
						269mm	
I5718H-1		TATA LPS 4928, LPTA 3138, LPK 2528, L/L 3119N, BHARAT BENZ 2523C, 2528C, 3128C, 4928TT COATED	4"	34		10.5"	6687407780 2130348
						269mm	



REAR HOUSING/SLEEVE BOTTLE

Part No.	Products	Application	Pipe Fitting Size	No. of Splines	Mating Long Fork	Total Length (L)	O.E.M Ref.
N/A		TATA LPS 4928, LPTA 3138, LPK 2528, L/L3119N, BHARAT BENZ 2523C, 2528C, 3128, 4928TT	4"	34		8.5"	
						218mm	
N/A		TATA LPS 4928, LPTA 3138, LPK 2528, L/L3119N, BHARAT BENZ 2523C, 2528C, 3128, 4928TT COATED	4"	34		8.5"	
						218mm	
N/A		TATA LPS 4021, MAHINDRA NAVISTAR-4026, LEYLAND ULE 390	4.5"	34			6687407080 2040261
N/A		TATA LPS 4021, MAHINDRA NAVISTAR-4026, LEYLAND ULE 390 COATED	4.5"	34			6687407080 2040261
N/A		TATA LPS 4028, LPK 3128, L/L 3123, BHARAT BENZ 2523C, 4023TT, EICHER TERRA 25T, MAN CLA 18.28	4.5"	38			6687457080 2030273
N/A		TATA LPS 4028, LPK 3128, L/L 3123, BHARAT BENZ 2523C, 4023TT, EICHER TERRA 25T, MAN CLA 18.28 COATED	4.5"	38			6687457080 2030273
N/A		TATA LPTA 1828, LPU 3128, L/L HMV 6X6 SHA-8T MERITOR AXLE, EICHER TIPPER 25T 250HP	4.5"	38			6687457080 2030273
N/A		TATA LPTA 1828, LPU 3128, L/L HMV 6X6 SHA-8T MERITOR AXLE, EICHER TIPPER 25T 250HP COATED	4.5"	38			6687457080 2030273
N/A		TATA LPTA-1628, 2038-L/L 4936, BHARAT BENZ LTPA-1628, LTPA 2038	4.5"	38			6687557080 2000294
N/A		TATA LPTA-1628, 2038-L/L 4936, BHARAT BENZ LTPA-1628, LTPA 2038 COATED	4.5"	38			6687557080 2000294

REAR HOUSING/SLEEVE BOTTLE

Part No.	Products	Application	Pipe Fitting Size	No. of Splines	Mating Long Fork	Total Length (L)	O.E.M Ref.
N/A		TATA LPK 3138, L/L-FV-2636, EICHER 407 TIPPER	4.5"	40			6687607080 2000310
N/A		TATA LPK 3138, L/L-FV-2636, EICHER TIPPER COATED	4.5"	40			6687607080 2000310
N/A		TATA 2518/4018	4.75"	36		8"	
N/A		TATA 2518/4018 COATED	4.75"	36		8"	
N/A		TATA 2518/4018	4.5"	36		8"	
N/A		TATA 2518/4018 COATED	4.5"	36		8"	
N/A		TATA L/L 1710 SERIES INTERAXLE	4"	16		10" 258mm	INSKU 100727
N/A		TATA L/L 1710 SERIES INTERAXLE COATED	4"	16		10" 258mm	INSKU 100727

REAR HOUSING WITH WELCH PLUG

Part No.	Products	Application	Cross Ref.	No. of Splines	Total Length(L)	Mating Part	O.E.M Ref.
N/A		LONG YOKE AMW 2518 Interaxle Shaft Spicer Type	41.28x126 4104GP	16	14"	15314 + 15709-A	
N/A		LONG YOKE AMW 2518 Interaxle Shaft	41.28x126 4104GP	16	15"	15314 + 15709-A	
N/A		SLEEVE BOTTLE AMW 2518	42x129 4054BP2	20	12"	15362G-5 + 15342-D	
I5343A		SLEEVE BOTTLE ASSLY TATA 2523	42x129 4054CP	20	13"	15362G-5 + 15342-F	
N/A		SLEEVE BOTTLE AMW 2518 Interaxle Shaft RSB	42x129 4054BP2	20	14"	15362G-5 + 15342-F	
I5343B		SLEEVE BOTTLE AMW 2518 Interaxle Shaft RSB	42x129 4054BP2	20	15.5"	15362G-5 + 15342-E	
N/A		SLEEVE BOTTLE ASSLY TATA 2523	48x135 4054CP	30	13.75"	15718 + 15720	
N/A		SLEEVE BOTTLE TATA 2523	48x135 4054CP	30	14.75"	15718 + 15720BP	
N/A		SLEEVE BOTTLE TATA 2523	48x135 4054CP	30	15"	15718 + 15720BP	

MOD[®] PLUS

TATA







YOKE & TEETH SET

Part No.	Products	Application	UJ Cross	Cross Ref.	No. of Splines	Pipe Dia	Mating Housing	O.E.M Ref.
I3509		TATA 1210	1210 38mm	4050P	10	2.5"	S.YOKE I3500	
							R.TEETH I3504	
N/A		TATA 1210 COATED	1210 38mm	4050P	10	2.5"	S.YOKE I3500	
							R.TEETH	
I3590		TATA 1210 SE	1210 38mm	4050P	10	3.0"	S.YOKE I3563	
							R.TEETH I3581	
N/A		TATA 1210 SE COATED	1210 38mm	4050P	10	3.0"	S.YOKE I3563	
							R.TEETH	
I3644		TATA 1312 1612/1510 2416/2213	1312 46mm	4054P	16	3.5"	S.YOKE I3630	
							R.TEETH I3635A	
I3644A		TATA 1312 1612/1510 2416/2213 COATED	1312 46mm	4054P	16	3.5"	S.YOKE I3630	
							R.TEETH I3635B	
N/A		TATA 1312 LONG	1312 46mm	4054P	16	3.5"	S.YOKE I5376	
							R.TEETH I5377	
I3644B		TATA 1312 LONG COATED	1312 46mm	4054P	16	3.5"	S.YOKE I5376	
							R.TEETH	
I3644C		TATA 1613	1312 46mm	4054P	24	3.5"	S.YOKE I3644-D	
							R.TEETH I3644-E	
N/A		TATA 1613 COATED	1312 46mm	4054P	24	3.5"	S.YOKE I3644-D	
							R.TEETH	

MOD[®] PLUS

TATA









YOKE & TEETH SET

Part No.	Products	Application	UJ Cross	Cross Ref.	No. of Splines	Pipe Dia	Mating Housing	O.E.M Ref.
N/A		TATA INTERAXLE L/L 2516	TUSKER 34.92X126	4104P	16	3.5"	S.YOKE 15369 R.TEETH 15370	INSKU 100449/ 100447
N/A		TATA INTERAXLE L/L 2516 COATED	TUSKER 34.92X126	4104P	16	3.5"	S.YOKE 15369 R.TEETH	INSKU 100449/ 100447
N/A		TATA 2516 LPK	L/L 2214 41.28X126	4104GP	30	3.5"	S.YOKE 15363 R.TEETH 15364	INSKU 100256 100524
I5364A		TATA 2516 LPK COATED	L/L 2214 41.28X126	4104GP	30	3.5"	S.YOKE 15363 R.TEETH	INSKU 100256 100524
N/A		TATA 1613,LPI613 THICK SPLINE 8" SMALL	L/L 2214 41.28X126	4104GP	16	4.0"	S.YOKE 15349-D R.TEETH 15349-F	
N/A		TATA 1613,LPI613 THICK SPLINE 8" SMALL COATED	L/L 2214 41.28X126	4104GP	16	4.0"	S.YOKE 15349-D R.TEETH	
N/A		TATA 4018	4018(PT) 49X154.5	4054DP	16	4.0"	S.YOKE 15362-B R.TEETH	6-3-2671KX 6-40-541
N/A		TATA 4018 COATED	4018(PT) 49X154.5	4054DP	16	4.0"	S.YOKE 15362-B R.TEETH 15362C	6-3-2671KX 6-40-541
N/A		TATA 4018/3118 AMW 2521,2518 MAN 25T	4018(PT) 49X154.5	4054DP	16	4.0"	S.YOKE 15362B-1 R.TEETH 15362B-2	6-3-2651KX 6-40-521
I5362B3		TATA 4018/3118 AMW 2521,2518 MAN 25T COATED	4018(PT) 49X154.5	4054DP	16	4.0"	S.YOKE 15362B-1 R.TEETH 15709	6-3-2651KX 6-40-521

MOD[®] PLUS

TATA

YOKE & TEETH SET

Part No.	Products	Application	UJ Cross	Cross Ref.	No. of Splines	Pipe Dia	Mating Housing	O.E.M Ref.
I3909		TATA 407	407 30X81.80	4036P	16	2.0"	S.YOKE I3900	
							R.TEETH I3905	
I3909B		TATA 407 COATED	407 30X81.80	4036P	16	2.0"	S.YOKE I3900	
							R.TEETH	
N/A		YOKE 407+ LONG TEETH WITH BRG 6207/88507	407 30X81.80	4036P	16	2.5"	S.YOKE I3900	
							R.TEETH I3909A1	
I3909A		YOKE 407+ LONG TEETH WITH BRG 6207/88507 COATED	407 30X81.80	4036P	16	2.5"	S.YOKE I3900	
							R.TEETH I3909A2	
I4251B		TATA 407 TURBO BEARING 88507	JEEP 27X81.80	4009P	16	2.5"	S.YOKE	
							R.TEETH	
I3909C I4251C		TATA 407 TURBO BEARING 88507 COATD	JEEP 27X81.80	4009P	16	2.5"	S.YOKE	
							R.TEETH	
I4018D		TATA 407 TURBO BEARING 6207/88507	CHEVROLET 30.20X92	4153P	16	3.0"	S.YOKE I4020	MSL 3320207 33409
							R.TEETH I4020A	
I4018E		TATA 407 TURBO BEARING 6207/88507 COATED	CHEVROLET 30.20X92	4153P	16	3.0"	S.YOKE I4020	MSL 3320207 33409
							R.TEETH I4020B	
I4018F		TATA 407 TURBO EX/709/909 BRG-6208/88508	CANTER 30.20X106	4131P 4132P	16	3.0"	S.YOKE I4026	
							R.TEETH	
I4018C		TATA 407 TURBO EX/709/909 BRG-6208/88508 COATED	CANTER 30.20X106	4131P 4132P	16	3.0"	S.YOKE I4026	
							R.TEETH I3923-B	

MOD[®] PLUS

TATA



YOKE & TEETH SET

Part No.	Products	Application	UJ Cross	Cross Ref.	No. of Splines	Pipe Dia	Mating Housing	O.E.M Ref.
N/A		TATA 407 TURBO 709/909 BS-III CITYRIDE BUS (6 WHEELER) BRG-6207/88507	CANTER 30.20X106	4131P 4132P	16	3.0"	S.YOKE I3910-A R.TEETH	
I3910		TATA 407 TURBO 709/909 BS-III CITYRIDE BUS (6 WHEELER) BRG-6207/88507 COATED	CANTER 30.20X106	4131P 4132P	16	3.0"	S.YOKE I3910-A R.TEETH I3910-B	
N/A		YOKE & TEETH SET 407 TURBO N/M MSL BRG 88508/6208	TUSKER 34.92X126	4104P	16	3.0"	S.YOKE I3887-C R.TEETH	
I3887		YOKE & TEETH SET 407 TURBO N/M MSL BRG 88508/6208 COATED	TUSKER 34.92X126	4104P	16	3.0"	S.YOKE I3887-C R.TEETH I3923-B	
N/A		TATA I109 EX EURO-II/EURO-III TATA 909 EURO-III	TUSKER 34.92X126	4104P	27	3.5"	S.YOKE I3869-C R.TEETH	
I3869		TATA I109 EX EURO-II/EURO-III TATA 909 EURO-III COATED	TUSKER 34.92X126	4104P	27	3.5"	S.YOKE I3869-C R.TEETH I3869-D	
N/A		TATA 709/712 TATA I109/909 MARCOPOLO BEARING 6210/88510	1210 38mm	4050P	22	2.5"	S.YOKE I3878A R.TEETH	
I3878		TATA 709/712 TATA I109/909 MARCOPOLO BEARING 6210/88510 COATED	1210 38mm	4050P	22	2.5"	S.YOKE I3878A R.TEETH I3878B	
N/A		TATA 407 PICK UP BS-II/EURO-III	407 PICK UP 34.92X106	4050-I	16	3.5"	S.YOKE R.TEETH	
I4018G		TATA 407 PICK UP BS-II/EURO-III COATED	407 PICK UP 34.92X106	4050-I	16	3.5"	S.YOKE R.TEETH	



MOD[®] PLUS

TATA

YOKE & TEETH SET

Part No.	Products	Application	UJ Cross	Cross Ref.	No. of Splines	Pipe Dia	Mating Housing	O.E.M Ref.
N/A		TATA 407 PICK UP BS-II/EURO-III	407 PICK UP 34.92X106	4050-I	16	3.0"	S.YOKE	
							R.TEETH	
I4019A		TATA 407 PICK UP BS-II/EURO-III COATED	407 PICK UP 34.92X106	4050-I	16	3.0"	S.YOKE	
							R.TEETH	
N/A		YOKE & TEETH TATA 909	SPL 055	4050-I	22-T	3.5"	S.YOKE	
					24-T		R.TEETH	
I4017		YOKE & TEETH TATA 909 COATED	SPL 055	4050-I	22-T	3.5"	S.YOKE	
					24-T		R.TEETH	

EICHER

I4018		EICHER CANTER	CATNER 30.20X106	4131P 4132P	16	3"	S.YOKE I4026	
							R.TEETH I4035	
I4018A		EICHER CANTER COATED	CATNER 30.20X106	4131P 4132P	16	3"	S.YOKE I4026	
							R.TEETH I4035A	
N/A		YOKE & TEETH SET EICHER TERRA	TUSKER 34.92X126	4104P	28	3.5"	S.YOKE I5354	
							R.TEETH I5355	
N/A		YOKE & TEETH SET EICHER TERRA COATED	TUSKER 34.92X126	4104P	28	3.5"	S.YOKE	
							R.TEETH	

MOD[®] PLUS

LEYLAND







YOKE & TEETH SET

Part No.	Products	Application	UJ Cross	Cross Ref.	No. of Splines	Pipe Dia	Mating Housing	O.E.M Ref.
N/A		L/L 1613 TURBO SMALL	L/L 2214 41.28X126	4104GP	30	3.5"	S.YOKE I5316C R.TEETH I5316D	
I5316F		L/L 1613 TURBO SMALL COATED	L/L 2214 41.28X126	4104GP	30	3.5"	S.YOKE I5316C R.TEETH	
N/A		TATA 2515/2518 L/L-2214,2516/3516 EICHER GALAXY (THIN SPLINE) BIG	L/L 2214 41.28X126	4104GP	30	4.0"	S.YOKE I5315 R.TEETH I5316	INSKU 100275 INSKU 100276
I5316A		TATA 2515/2518 L/L-2214,2516/3516 EICHER GALAXY (THIN SPLINE) BIG COATED	L/L 2214 41.28X126	4104GP	30	4.0"	S.YOKE I5315 R.TEETH I5316B	INSKU 100275 INSKU 100276
N/A		L/L 1613 TURBO SMALL	L/L 2214 41.28X126	4104GP	16	3.5"	S.YOKE I5349D R.TEETH I5349E	
N/A		L/L 1613 TURBO SMALL COATED	L/L 2214 41.28X126	4104GP	16	3.5"	S.YOKE I5349D R.TEETH	
I5352		TATA 2515/2518 L/L-2214,2516/3516 EICHER GALAXY (THICK SPLINE) BIG	L/L 2214 41.28X126	4104GP	16	4.0"	S.YOKE I5345 R.TEETH I5349A	
I5349C		TATA 2515/2518 L/L-2214,2516/3516 EICHER GALAXY (THICK SPLINE) BIG COATED	L/L 2214 41.28X126	4104GP	16	4.0"	S.YOKE I5345 R.TEETH I5349B-1	
N/A		L/L TUSKER 3" EICHER 11.10 XP	TUSKER 34.92X126	4104P	16	3.0"	S.YOKE I4994 R.TEETH I4832	
I4994C		L/L TUSKER 3" EICHER 11.10 XP COATED	TUSKER 34.92X126	4104P	16	3.0"	S.YOKE I4994 R.TEETH I4994E	

MOD[®] PLUS

LEYLAND

YOKE & TEETH SET

Part No.	Products	Application	UJ Cross	Cross Ref.	No. of Splines	Pipe Dia	Mating Housing	O.E.M Ref.
N/A		L/L TUSKER-3.5" EICHER 11.14 PRO	TUSKER 34.92X126	4104P	16	3.5"	S.YOKE 14994 R.TEETH 14836	
I4994D		L/L TUSKER-3.5" EICHER 11.14 PRO COATED	TUSKER 34.92X126	4104P	16	3.5"	S.YOKE 14994 R.TEETH 14994F	
N/A		L/L 1613 TURBO	TUSKER 34.92X126	4104P	16	3.5"	S.YOKE 14994A R.TEETH	
I4994BP		L/L 1613 TURBO COATED	TUSKER 34.92X126	4104P	16	3.5"	S.YOKE 14994A R.TEETH 14994B-2	
N/A		L/L 1613 TURBO HEAVY DUTY	TUSKER 34.92X126	4104P	16	3.5"	S.YOKE 14995C R.TEETH	
I4995		L/L 1613 TURBO HEAVY DUTY COATED	TUSKER 34.92X126	4104P	16	3.5"	S.YOKE 14995C R.TEETH 14995B	
N/A		L/L E-COMET L/L STAG	TUSKER 34.92X126	4104P	16	3.5"	S.YOKE 14995D R.TEETH	
N/A		L/L E-COMET L/L STAG COATED	TUSKER 34.92X126	4104P	16	3.5"	S.YOKE 14995D R.TEETH 14994-B	
N/A		L/L TAURUS	L/L TAURUS 47.62X135	4104EP	16	3.5"	S.YOKE 15142 R.TEETH 15124	
N/A		L/L TAURUS COATED	L/L TAURUS 47.62X135	4104EP	16	3.5"	S.YOKE 15142 R.TEETH 15124	

MOD[®] PLUS

TATA

**SLIP YOKE ASSY./
SLEEVE YOKE**

Part No.	Products	Application	UJ Cross	Cross Ref.	No. of Splines	Pipe Dia	Mating Housing	O.E.M Ref.
I3500		TATA I210	I210 38mm	4050P	10	8.00"	I3504	312-410-1908
						207 mm		
I3563		TATA I210 SE	I210 38mm	4050P	10	8.25"	I3581	312-410-2108
						215 mm		
I3878A		TATA-712 TATA 1109/909 MARCOPOLO BUS	I210 38mm	4050P	22	8.00"	I3878B	
						206 mm		
I3630		TATA I312/1612 2416/2213	I312 46mm	4054P	16	10.25"	I3635-A	2576 4112 5104
						265 mm		
I5376		TATA I312 LONG	I312 46mm	4054P	16	12.50"	I5377	
						309 mm		
I3644D		TATA I613 TURBO 1109	I312 46mm	4054P	24	10.25"	I3644-E	
						265 mm		
I5315		TATA 2515 EX, 2518 L/L-2214,2516,3516 EICHER GALAXY BIG	2518 41.28X126	4104GP	30	12.00"	I5316	INSKU 100257
						295 mm		
I5369		TATA INTERAXLE 2516	TUSKER 34.92X126	4104P	16	14.00"	I5370	INSKU 100448
						356 mm		
N/A		TATA HYWA (2515/3516)	TUSKER 34.92X126	4104P	28	12.50"		INSKU 100377
						315 mm		
I3869C		TATA 1109 BS-III TATA 909 EURO-III	TUSKER 34.92X126	4104P	27	9.50"	I3869-D	
						240 mm		

MOD[®] PLUS

TATA











**SLIP YOKE ASSY./
SLEEVE YOKE**

Part No.	Products	Application	UJ Cross	Cross Ref.	No. of Splines	Pipe Dia	Mating Housing	O.E.M Ref.
I3887C		TATA 407 TURBO 709/909 EURO-II MARCOPOLO	TUSKER 34.92X126	4104P	16	8.00"	I3923B	
						200 mm		
I5362B		TATA 4018 L/L 2516	4018(PT) 49.2X154.5	4054DP	16	11.25"	I5362C	6-7-2671 KX
						281 mm		
I5362B-1		TATA 3118,4018 2518/2521 AMW 2518 MAN 25T LONG	4018(PT) 49.2X154.5	4054DP	16	13.00"	I5709/ I5362B2	6-3-2651 KX
						329 mm		
I3900		TATA 407	407 30X81.8	4036P	16	6.50"	I3905	2651 4110 0125
						168 mm		
I4020		TATA 407 N/M MSL TYPE	DCM CHEVROLET 30.20X92	4153P	16	7.00"	I4020B	MSL 3220207
						170 mm		
I4026		CANTER TAT 407 TURBO EX 709/909	CANTER 30.20X106	4131P 4132P	16	7.5"	I3923B	3-3-118 KX
						195 mm		
I3910A		TATA CITYRIDE BUS 407 TURBO 709/909 BS-III	CANTER 30.20X106	4131P 4132P	16	7.5"	I3910B	
						186 mm		
N/A		TATA 407 PICK UP	TATA 407 PICK UP	4050-I	16	8.00"		
						198 mm		
N/A		SLEEVE YOKE TATA 909 (24 SPLINE 2 KNOCK OFF)	34.92X106 SPR 55	4050-I	22	9"		
						225 mm		

MOD[®] PLUS

LEYLAND





SLIP YOKE ASSY./
SLEEVE YOKE

Part No.	Products	Application	UJ Cross	Cross Ref.	No. of Splines	Pipe Dia	Mating Housing	O.E.M Ref.
I5349D		L/L 3516/3014 TATA-1616/1613 SMALL	L/L 2214 41.28X126	4104GP	16	10.00"	15349-E	
						253 mm	15349-F	
I5345		TATA 2515 EX/2518 L/L 2214/2516/3516 (THICK SPLINE) BIG	L/L 2214 41.28X126	4104GP	16	12.00"	15349A	
						296 mm		
I5316C		L/L 3516/3014 TATA-1616/1613 SMALL	L/L 2214 41.28X126	4104GP	30	10.00"	15316-D	
						253 mm	15316-E	
I5315		TATA 2515 EX/2518 L/L 2214/2516/3516 (THIN SPLINE) BIG	L/L 2214 41.28X126	4104GP	30	12.00"	15316	INSKU 100256
						296 mm		
I4823		L/L 350/370 J4/J6 BEDFORD	L/L 370 39.67X115.4	4090P	16	8.00"	14832	K4-3GB-538
						202 mm	14836	
I4994		L/L TUSKER EICHER-1110 XP 11.14 PRO	TUSKER 34.92X126	4104P	16	8.00"	14832	P100432 4000239
						207 mm	14836	
I4994A		L/L 1613 TURBO EURO-II	TUSKER 34.92X126	4104P	16	9.75"	14994B-2	4-3-2641 X
						246 mm		
I4995C		L/L-1613 TURBO EURO-II HEAVY DUTY	TUSKER 34.92X126	4104P	16	9.75"	14995B	KF-6804
						246 mm		
I4995D		L/L E-COMET STAG	TUSKER 34.92X126	4104P	16	10.50"	14994B	4-3-1431 KX
						265 mm		
I5700		TATA L/L I/A 1710 SERIES	TUSKER 34.92X126	4104P	16	13.50"	15709	INSKU 100727
						341 mm		



MOD[®] PLUS

LEYLAND

SLIP YOKE ASSY./ SLEEVE YOKE

Part No.	Products	Application	UJ Cross	Cross Ref.	No. of Splines	Pipe Dia	Mating Housing	O.E.M Ref.
I5700A		TATA L/L I/A 1710 SERIES L/L-3116/1616	L/L 2214 41.28X126	4104GP	16	13.50"	15709 15709A	3-3-118KX
						359 mm		
N/A		TATA L/L I/A 1710 SERIES	L/L 2214 41.28X126	4104GP	16	13.00"	15709	
						325 mm		
I5142		L/L TAURUS	L/L TAURUS 47.62X135	4104EP	16	9.50"	15124	MSL SUK 5055
						240 mm		
N/A		L/L TAURUS LONG	L/L TAURUS 47.62X135	4104EP	16	10.50"		
						269 mm		

EICHER

I4026		CANTER TATA 407 TURBO EX 709/909	CANTER 30.20X106	4131P 4132P	16	7.5"	14035	3-3-118KX
						194 mm		
I5354		SLEEVE YOKE EICHER TERRA	TUSKER 34.92X126	4104P	28	11.5"	15355	
						290 mm		

MOD[®] PLUS

TATA









**SLIP STUB SHAFT/
REAR TEETH**

Part No.	Products	Application	No of Spline	Spline Dia	Pipe Dia	Total Length	Mating Yoke	O.E.M Ref.
I3504		TATA I210	10	44.70	2.50"	9.00"	I3500	313 410 1908
						224 mm		
N/A		TATA I210 COATED	10	44.70	2.50"	9.00"	I3500	313 410 1908
						224 mm		
I3581		TATA I210 SE	10	44.70	3.0"	9.00"	I3563	312 411 1702
						223 mm		
N/A		TATA I210 SE COATED	10	44.70	3.0"	9.00"	I3563	312 411 1702
						223 mm		
I3923A		TATA 407/I210 CONV SMALL HEAD	10	44.70	2.00"	9.00"	I3500	
						212 mm		
N/A		TATA 407/I210 CONV COATED	10	44.70	2.00"	9.00"	I3500	
						212 mm		
I3635A		TATA I312 I612 2213/I510	16	50.80	84mm	11.50"	I3630	INSKU 100256
						291 mm		
I3635B		TATA I312 I612 2213/I510 COATED	16	50.80	84mm	11.50"	I3630	
						291 mm		
I5377		TATA I312 LONG	16	50.80	3.5"	13.50"	I5376	
						338 mm		
N/A		TATA I312 LONG COATED	16	50.80	3.5"	13.50"	I5376	
						338 mm		

MOD[®] PLUS

TATA









**SLIP STUB SHAFT/
REAR TEETH**

Part No.	Products	Application	No of Spline	Spline Dia	Pipe Dia	Total Length	Mating Yoke	O.E.M Ref.
I5349E		TATA I613 SMALL	16		3.5"	9.00"	I5349-D	
						226 mm		
N/A		TATA I613 COATED	16		3.5"	9.00"	I5349-D	
						226 mm		
I5370		TATA INTERAXLE 2516	16		3.5"	12.50"		INSKU 100447
						313 mm		
N/A		TATA INTERAXLE 2516 COATED	16		3.5"	12.50"		INSKU 100447
						313 mm		
N/A		TATA 4018 AMW (SMALL)	16	63.80	4.0"	10.50"	I5362-B	6-40-541
						265 mm		
I5362C		TATA 4018 AMW (SMALL) COATED	16	63.80	4.0"	10.50"	I5362-B	6-40-541
						265 mm		
N/A		TATA L/L INTERAXLE 1710 SERIES HALF SPLINE	16	68.80	4.0"	12.00"	I5700	6-40-521
						297 mm		
I5709		TATA L/L INTERAXLE 1710 SERIES HALF SPLINE COATED	16	68.80	4.0"	12.00"	I5700	6-40-521
						297 mm		
I5709A		TATA L/L INTERAXLE 1710 SERIES WITH DUST COVER OIL SEAL FEATED COATED	16	68.80	4.0"	12.00"	I5700A	6-40-521
						297 mm		
I5709B		TATA L/L INTERAXLE 1710 SERIES HALF SPLINE COATED	16	68.80	4.0"	13.00"	I5700	6-40-521
						330 mm		

MOD[®] PLUS

TATA







**SLIP STUB SHAFT/
REAR TEETH**

Part No.	Products	Application	No of Spline	Spline Dia	Pipe Dia	Total Length	Mating Yoke	O.E.M Ref.
N/A		TATA 3118/4018 EXTRA LONG FULL SPLINE	16	68.80	4.00"	12.00" 297 mm	15362B-1	6-40-521
I5362B-2		TATA 3118/4018 EXTRA LONG FULL SPLINE COATED	16	68.80	4.00"	12.00" 297 mm	15362B-1	6-40-521
I5364		TATA LPK 2516 THIN SPLINE BIG	30	49.35	3.5"	10.50" 265 mm	15363	INSKU 100524
N/A		TATA LPK 2516 THIN SPLINE BIG COATED	30	49.35	3.5"	10.50" 265 mm	15363	INSKU 100524
I5316		TATA 2525 EX, 2518 L/L-2214,2516,3516 EICHER GALAXY BIG	30	49.35	4.0"	10.50" 266 mm	15315	
I5316B		TATA 2525 EX, 2518 L/L-2214,2516,3516 EICHER GALAXY BIG COATED	30	49.35	4.0"	10.50" 266 mm	15315	
I3644E		TATA I312 N/M TATA I613 TURBO/I109	24		84mm	11.50" 289 mm	13644-D	
N/A		TATA I312 N/M TATA I613 TURBO/I109 COATED	24		84mm	11.50" 289 mm	13644-D	
I3905		TATA 407	16	34.90	2.00"	6.90" 168 mm	13900	
N/A		TATA 407 COATED	16	34.90	2.00"	6.90" 168 mm	13900	

MOD[®] PLUS

TATA

**SLIP STUB SHAFT/
REAR TEETH**

Part No.	Products	Application	No of Spline	Spline Dia	Pipe Dia	Total Length	Mating Yoke	O.E.M Ref.
I3909A-1		TATA 407 TURBO N/M BEARING NO. 6207/88507	16	34.90	2.50"	9.00"	I3900	
						226 mm		
I3909A-2		TATA 407 TURBO N/M BEARING NO. 6207/88507 COATED	16	34.90	2.50"	9.00"	I3900	
						226 mm		
I4020-A		TATA 407 TURBO N/M MSL TYPE BEARING NO. 6207/88507	16	34.90	3.0"	8.00"	I4020	
						201 mm		
I4020-B		TATA 407 TURBO N/M MSL TYPE BEARING NO. 6207/88507 COATED	16	34.90	3.0"	8.00"	I4020	
						201 mm		
N/A		TATA 407 TURBO EX/709/909 BEARING NO. 6208/88508	16	38.10	3.00"	9.00"	I4026	INSKU 100214
						230 mm		
I3923B		TATA 407 TURBO EX/709/909 BEARING NO. 6208/88508 COATED	16	38.10	3.00"	9.00"	I4026	INSKU 100214
						230 mm		
N/A		TATA 407 TURBO CITYRIDE BUS TATA 709/909	16	38.10	3"	9.00"	I3910A	
						230 mm		
I3910-B		TATA 407 TURBO CITYRIDE BUS TATA 709/909 COATED	16	38.10	3"	9.00"	I3910A	
						230 mm		
N/A		TATA 712 TURBO BEARING NO. 6210/88510	22	47.10	2.50"	10.00"		
						251 mm		
I3878B		TATA 712 TURBO BEARING NO. 6210/88510 COATED	22	47.10	2.50"	10.00"	I3878A	
						251 mm		

MOD[®] PLUS

TATA

**SLIP STUB SHAFT/
REAR TEETH**

Part No.	Products	Application	No of Spline	Spline Dia	Pipe Dia	Total Length	Mating Yoke	O.E.M Ref.
N/A		TATA 1109 BEARING NO. 6209/88509	27		3.50"	11.00" 274 mm	13869-C	
13869D		TATA 1109 BEARING NO. 6209/88509 COATED	27		3.50"	11.00" 274 mm	13869-C	
N/A		TATA 407 PICK UP	16	38.10	3.50"	7.50" 192 mm		
N/A		TATA 407 PICK UP COATED	16	38.10	3.50"	7.50" 192 mm		
N/A		TATA 407 PICK UP	16		3.00"	7.50" 192 mm		
N/A		TATA 407 PICK UP COATED	16		3.00"	7.50" 192 mm		
N/A		REAR TEETH TATA 909	24		3.5"	8.75" 220 mm		
N/A		REAR TEETH TATA 909 COATED	24		3.5"	8.75" 220 mm		
15355		TATA HYWA	28		3.5"	11.50" 290 mm	15354	INSKU 100370
N/A		TATA HYWA COATED	28		3.5"	11.50" 290 mm		INSKU 100370

MOD[®] PLUS

LEYLAND







SLIP STUB SHAFT/
REAR TEETH

Part No.	Products	Application	No of Spline	Spline Dia	Pipe Dia	Total Length	Mating Yoke	O.E.M Ref.
I5316D		L/L 1613 TURBO SMALL	30	49.35	3.50"	9.00"	15316-C	
N/A		L/L 1613 TURBO SMALL COATED	30	49.35	3.50"	9.00"	15316-C	
I5316E		L/L-3516/3014/4018 TATA 1616/1613 SMALL	30	49.35	4.00"	9.00"	15316-C	
N/A		L/L-3516/3014/4018 TATA 1616/1613 SMALL COATED	30	49.35	4.00"	9.00"	15316-C	
I5316		TATA 2515 EX, 2518 L/L 2214/3516 EICHER GALAXY (BIG)	30	49.35	4.00"	10.50"	15315	INSKU 100276
I5316B		TATA 2515 EX, 2518 L/L 2214/3516 EICHER GALAXY (BIG) COATED	30	49.35	4.00"	10.50"	15315	INSKU 100276
I5349F		L/L 3516 (THICK SPLINE) SMALL	16	50.80	4.00"	9.00"	15349-D	
N/A		L/L 3516 (THICK SPLINE) SMALL COATED	16	50.80	4.00"	9.00"	15349-D	
I5349		TATA 2515 EX, 2518 L/L-2214/2516/3516 HALF SPLINE	16	50.8	4.00"	10.50"	15345	
I5349B		TATA 2515 EX, 2518 L/L-2214/2516/3516 HALF SPLINE COATED	16	50.8	4.00"	10.50"	15345	

MOD[®] PLUS

LEYLAND

SLIP STUB SHAFT/
REAR TEETH

Part No.	Products	Application	No of Spline	Spline Dia	Pipe Dia	Total Length	Mating Yoke	O.E.M Ref.
I5349A		L/L 2214/3516 FULL SPLINE	16	50.8	4.00"	10.50"	I5345	
I5349B-1		L/L 2214/3516 FULL SPLINE COATED	16	50.8	4.00"	10.50"	I5345	
I4832		L/L 350/370 TUSKER BEDFORD EICHER 11.10 EX FULL SPLINE	16	44.50	3.00"	8.00"	I4823	
						198 mm	I4994	
I4994E		L/L 350/370 TUSKER BEDFORD EICHER 11.10 EX FULL SPLINE COATED	16	44.50	3.00"	8.00"	I4823	
						198 mm	I4994	
I4836		L/L 350/370 TUSKER, BEDFORD EICHER 11.14 PRO	16	44.50	3.5"	8.00"	I4823	K-4-42- GT-1801
						200 mm	I4994	
I4994F		L/L 350/370 TUSKER, BEDFORD EICHER 11.14 PRO COATED	16	44.50	3.5"	8.00"	I4823	
						200 mm	I4994	
N/A		L/L 1613 TURBO STAG E-COMET	16	44.50	3.5"	9.20"	I4994-A	
						222 mm		
I4994B-2		L/L 1613 TURBO STAG E-COMET COATED	16	44.50	3.5"	9.20"	I4994-A	
						222 mm		
N/A		L/L 1613 TURBO STAG E-COMET HEAVY DUTY THICK SPLINE	16	50.80	3.5"	9.20"	I4995-C	
						222 mm		
I4995B		L/L 1613 TURBO STAG E-COMET HEAVY DUTY THICK SPLINE COATED	16	50.80	3.5"	9.20"	I4995-C	
						222 mm		



MOD[®] PLUS

LEYLAND

SLIP STUB SHAFT/ REAR TEETH

Part No.	Products	Application	No of Spline	Spline Dia	Pipe Dia	Total Length	Mating Yoke	O.E.M Ref.
N/A		L/L STAG E-COMET BUS	16	44.50	3.5"	10.00" 254 mm	14995-D	
14994B		L/L STAG E-COMET BUS COATED	16	44.50	3.5"	10.00" 254 mm	14995-D	
15124		L/L TAURUS	16	50.80	3.5"	8.50" 226 mm	15142	
N/A		L/L TAURUS COATED	16	50.80	3.5"	8.50" 226 mm	15142	
N/A		L/L TAURUS LONG N/M	16	50.80	3.5"	10.50" 266 mm		
N/A		L/L TAURUS LONG N/M	16	50.80	3.5'	10.50" 266 mm		

EICHER

14035		EICHER CANTER	16	38.10	3.0"	6.75" 170 mm	14026	
14035A		EICHER CANTER COATED	16	38.10	3.0"	6.75" 170 mm	14026	
15355		REAR TEETH EICHER TERRA	28		3.5"	10.5" 270 mm	15355	

MOD[®] PLUS

DUST COVER

Part No.	Products	Application	O.E.M Ref.
N/A		FOR RSB 325, 403 SERIES, 2515/2518	F621 325 081 140, 2171 4112 0128
I5344		FOR RSB 403 SERIES LONG	
N/A		FOR RSB 490 SERIES, 4018/3118	F621 490 089 130, 2846 4112 0103
I5721		FOR RSB 490 SERIES LONG	
N/A		SPICER SERIES 2040 (I&S)	66874077802130348
N/A		SPICER SERIES 2040	6687407080204061
N/A		SPICER SERIES 2045	66874570802030273
N/A		SPICER SERIES 2047	66874570802030273
N/A		SPICER SERIES 2055	66875570802000
N/A		SPICER SERIES 2060	66876070802000310

MOD[®] PLUS

TATA

MID SLIP STUB
SHAFT / FRONT TEETH

Part No.	Products	Application	No of Spline	Pipe Dia	Total Length	O.E.M Ref.
I3932		TATA 407	16	2.0"	7.0"	(35mm) 6207
					175 mm	
I3518		TATA I210	14	2.5"	8.0"	313 411 1702 Bearing (40 mm) 6208
					191 mm	
I3599		TATA I210 SE	14	3.0"	8.0"	313 411 1702 Bearing (40 mm) 6208
					191 mm	
I3684A		TATA I312 (72 mm)	26	3.0"	8.0"	Bearing (55 mm) 6211
					195 mm	
I3684		TATA I312 (90 mm) 2416	26	3.5"	8.0"	2576 4111 5104 Bearing (55 mm) 6211
					200 mm	
I5377H		TATA 2518/2515 2416/L/L BIG HEAD	26	4.0"	8.0"	INSKU-100853 Bearing (55 mm) 6211
					195 mm	
I5377J		TATA 2515/2518/ 2416 L/L BIG HEAD DOUBLE STEP (WITH LONG COLLER)	26	4.0"	8.0"	BEARING (55mm) 6211
					198 mm	
I5377K		TATA 2518 N/M, 1613, 1616 LONG COLLER	26	3.5"	8.0"	BEARING (55 mm) 6211
					198 mm	
I5377-I		TATA 2518,3118/LEYLAND-3116 BEARING 6013 DOUBLE STEP	26	4.0"	7.0"	BEARING (65mm) 6013
					175 mm	
I5377-L		TATA 2518 (BEARING 6211)	26	4.0"	7.0"	BEARING (55mm) 6211

MOD[®] PLUS

TATA







**MID SLIP STUB
SHAFT / FRONT TEETH**

Part No.	Products	Application	No of Spline	Pipe Dia	Total Length	O.E.M Ref.
I5358A		TATA 1616/1613 (BEARING NO. 6211)	34	3.50"	6.5"	INSKU 90-53-0020
					159 mm	
I5377G		TATA 2518 N/M, L/L 3516 (BEARING NO. 6211)	34	4.0"	6.5"	BEARING (55mm) 6211
N/A		TATA 2515/3516 BEARING NO. 88509	34	3.5"	6.5"	Bearing (45MM) 88509
					159 mm	
I5724A		TATA 3118	16	4.0"	7.5"	BEARING (60mm) 6012
					189 mm	
N/A		TATA 4018	16	4.5"	7.5"	
					190 mm	
I5377N		TATA 2518/3118/3718 AL 3119	20	4.0"	6"	6012 (60mm)
I5377M		TATA 3128/3123/3721 3723/3718/2523	20	4.5"	6.0"	BEARING (55mm) 6211
I5377P		TATA LPK 3118/4923 RSB 690	30	4.5"	9"	BEARING (75mm) 6015
I4094		EICHER CANTER 10.50,10.70, 10.90	10	3.0"	5.5"	
					146 mm	
I4095		EICHER 11.10/11.12/11.14 XP.	16	3.5"	7"	BEARING (55MM) 6211
					180 mm	

MOD[®] PLUS

LEYLAND

MID SLIP STUB
SHAFT / FRONT TEETH

Part No.	Products	Application	No of Spline	Pipe Dia	Total Length	O.E.M Ref.
I5358		TATA 2515 EX, 2518 L/L 2214/2516/3116 EICHER (BRG 88509)	34	4.0"	6.5"	90-53-31 BEARING (45mm) 88509/6209
					160 mm	
I4841 I5016		LEYLAND TUSKER 3" L/L 370/350	10	3.0"	8.25"	P 1502733 BEARING (45MM) 6209
					207 mm	
I4845 I5021		LEYLAND TUSKER 3.5"	10	3.50"	9.0"	P 1502535 BEARING (45MM) 6209
					224 mm	
I4535		TATA 1510 TC, (6209) L/L 1613 TURBO/COMMET/STAG LYNX/20.16 (HEAVY DUTY)	10	3.5"	6.0"	INSKU-100557 SDMT1550D95 Bearing (45 mm)
					144 mm	
I5300		LEYLAND TAURUS EICHER 30.25, GALAXY	16	3.50"	7.0"	BEARING (55MM) 6211
					180 mm	
I4094		FRONT TEETH EICHER CANTER	10	3.0"	5.5"	
					146 mm	
I4125		FRONT TEETH SWARAJ MAZDA	34	3.0"		

MOD[®] PLUS

TATA











TUBE YOKE / HALF YOKE

Part No.	Products	Application	UJ Cross	Cross Ref.	Pipe Dia	Height	O.E.M Ref.
I3513		TATA I210	I210 38mm	4050P	2.5"	120 mm	2573 4111 5115
I3594		TATA I210 SE	I210 38mm	4050P	3.0"	120 mm	2573 4111 5115
I3923		TATA 407/ I210 CONVT.	I210 38mm	4050P	2.0"	123 mm	
I3918		TATA 407	407 30X82	4036P	2.0"	93 mm	
I3680A		TATA I312 (72 MM)	I312 46mm	4054P	3.0"	137 mm	
I3680		TATA I312 (90 MM)	I312 46mm	4054P	3.5"	136 mm	2576 4111 5109
I3869B		TATA I109/909	TUSKER 34.92X126	4104P	3.5"	105 mm	
I5340A		TATA INTERAXLE L/L TUSKER L/L 2214/2514 TIPPER	TUSKER 34.92X126	4104P	4.0"	110 mm	INSKU 1009663 / 975
I5700C		TATA I710 SERIES INTERAXLE L/L TUSKER L/L 2214/2516 EXTRA LONG	TUSKER 34.92X126	4104P	4.0"	135 mm	
I5374B		TATA LPK 2516, 1615	L/L 2214 41.28X126	4104GP	3.5"	135 mm	INSKU 100232

MOD[®] PLUS

TATA



TUBE YOKE / HALF YOKE

Part No.	Products	Application	UJ Cross	Cross Ref.	Pipe Dia	Height	O.E.M Ref.
I5340B-1		RSB 2515 EX (325 SERIES)	RSB 325 42X120	4054AP 4050AP2	3.5"	127 mm	2632 4140 5106
I5340B-3		RSB-325 TATA 2515 EX PIPE SIZE-4"	RSB 325 42X120	4054AP 4050AP2	4.0"	129 mm	
I5362G-4		RSB-403 SERIES	RSB 403 42X129	4054BP2	3.5"	137 mm	
I5362G-1		RSB-403 TATA 2518	RSB 403 42X129	4054BP2	4.0"	137 mm	2171 4112 5105
I5362G-5		RSB-403 TATA 2518 LONG HEIGHT HT-145MM	RSB 403 42X129	4054BP2	4.0"	147 mm	
I5362A-1		TATA 4018/3118 L.P.O 1623/1618 1615/1625/L/L2515 3213/3118 MAN25T	4018(PT) 49.2X154.8	4054DP	4.0"	140 mm	6-28-347
I4215		TATA 407 TML/MSM 900	DCM Chevrolet 30.20x92.1	4153P	3.0"	95 mm	
I4053		TATA 407 TURBO EX 909,709 LPK EICHER CANTER	CANTER 30.20X106	4131P 4132P	3.0"	97 mm	3-28-267
I3912		TATA 407 PICK UP	34.92X106	4050-I	3.5"	96 mm	
I3911		TATA 407 PICK UP	34.92X106	4050-I	3.0"		

MOD[®] PLUS

TATA

TUBE YOKE / HALF YOKE

Part No.	Products	Application	UJ Cross	Cross Ref.	Pipe Dia	Height	O.E.M Ref.
15718		RSB 490 TATA L/L-2518/3118	RSB 490 48X135	4054CP	4.0"	145 mm	2161 4112 5102
15718-I		TATA LPS 4928, LPTA 3138, LPK528 L/L3119N, BHARAT BENZ 2523C 2528C, 3128C 4928TT	SPR2040 47.68X135.10	4054EP	4.0"		6687407080 2040261
15930B		TATA LPS 4028, LPK 3128, L/L 3123 BHARAT BENZ 2523C 4023TT, EICHER TERRA 25T, MAN CLA 18.28	SPR2045 52X147.2	4122-A	4.5"		6687457080 2030273
N/A		TATA LPTA 1828, LPO 2138, L/L HMV6X6 SHA-8T MERITOR AXLE, EICHER TIPPER 25T 2502HP MAN LPTA 1828 6X6	SPR2047 52X147.2	4122-A	4.5"		6687457080 2070273
N/A		TATA LPTA-1628, 2038-L/L 4936, BHARAT BENZ LTPA-1628, LTPA 2038	SPR2055 57X152	4113-A	4.5"		6687557080 2000294
N/A		TATA LPK 3138, L/L-FV-2636, EICHER 40T TIPPER MAN 31.28	SPR2060 59X167.7		4.5"		6687607080 2000310

MOD[®] PLUS

LEYLAND

TUBE YOKE / HALF YOKE

Part No.	Products	Application	UJ Cross	Cross Ref.	Pipe Dia	Height	O.E.M Ref.
I5314		TATA 2515 EX 1616 L/L 2214/2516/3516/ 3116 EICHER GALAXY	L/L 2214 41.28X126	4104GP	4.0"	128 mm	90-28-27
I5700B		TATA 1616 SE BS-III/4200B L/L INTERAXLE EXTRA LONG	L/L 2214 41.28X126	4104GP	4.0"	145 mm	
I4854		L/L 350/370, 3" BEDFORD J-4-J-6	L/L 370 39.67X115.4	4090P	3.0"	125 mm	K4-26-GB-477
I4859		L/L 350/370, 3.5" BEDFORD	L/L 370 39.67X115.4	4090P	3.5"	134 mm	K4-26-GB-577
I4985		L/L TUSKER 3" EICHER-11.10 XP	TUSKER 34.92X126	4104P	3.0"	113 mm	P 1500 114 F2134011
I5003		L/L TUSKER 3.5" EICHER-11.14 PRO	TUSKER 34.92X126	4104P	3.5"	106 mm	P 1500 114 F2134311 P4200234
I5138		L/L TAURUS	L/L Taurus 47.62X135	4104EP	3.5"		90-28-27

EICHER

I4053		EICHER CANTER TATA 709/909	CANTER 30.20X106	4131P 4132P	3.0"		

MOD[®] PLUS

TATA











**FLANGE YOKE /
CROSS HOLDER**

Part No.	Products	Application	UJ Cross Cross Ref.	Hole Size	No. of Holes	Bolt Size	Plate Size	Height MM	O.E.M Ref.
265A		TATA 1210	1210 38 MM 4050P	10.20	6	17No.	4.72"	90	312 411 1111
							120 mm		
265B		TATA 712	1210 38 MM 4050P	10.20	8	17No.	5"	86	312 411 1111
							130 mm		
265C		TATA 1210 N/M	1210 38 MM 4050P	16.20	8	17No.	4.72"	90	
							120 mm		
I3653A		TATA 1312 N/M, TIPPER	1312 46 MM 4054P	10.20	6	17No.	5"	114	
							120 mm		
I3653		TATA 1312/1612 2416/2213	1312 46 MM 4054P	10.20	8	17No.	5"	115	2576 4111 5110
							130 mm		
I5374A		TATA 2515 EX (BIG NUT)	L/L 2214 41.28X126 4104GP	10.20	8	17No.	5"	113	INSKU 100860
							130 mm		
I5377A		TATA 2518 LPO 1616 BUS 1625 BUS LPO 1628/LPO 2521	L/L 2214 41.28X126 4104GP	12.10	8	19No.	6"	116	SDFY1710D165 90-2-29
							150 mm		
I5313B		TATA 3118/2521 L/L 3116/1616 AMW 2518/MAN 25T HT.100MM (SERATED)	L/L 2214 41.28X126 4104GP	13.00	4	19No.	6"	104	SDFY0090D150T 90-2-15 2809 4110 3703
							150 mm		
I5313BP		TATA 3118/2521 L/L 3116/1616 AMW 2518/MAN 25T HT.110MM (SERATED)	L/L 2214 41.28X126 4104GP	13.00	4	19No.	6"	110	
							150 mm		
I5313B-1		TATA 1616 AC BS-III-4200B L/L 2516 INTERAXLE EXTRA LONG (SERATED)	L/L 2214 41.28X126 4104GP		4		6"	118	
							150 mm		

MOD[®] PLUS

TATA











**FLANGE YOKE /
CROSS HOLDER**

Part No.	Products	Application	UJ Cross Cross Ref.	Hole Size	No. of Holes	Bolt Size	Plate Size	Height MM	O.E.M Ref.
I5336A		TATA 2518 TC N/M TUSKER LONG	L/L 2214 41.28X126 4104GP	12.80	4	21No.		105	
I5336		TATA 2515 TC L/L 2516, TUSKER LONG INTERAXLE	TUSKER 34.92X126 4104P	12.80	4	21No.	SQR	105	SDFY1550IAD121 INSKU 10082
I3887B		TATA 1109	TUSKER 34.92X126 4104P	10.00	6	17No.	5" 120 mm	90	
I3869A		TATA 1109	TUSKER 34.92X126 4104P	10.00	8	17No.	5" 130 mm	115	VDFY0070D130 10021223
I3914		TATA 407	407 30X82 4036P	8.20	6	13No.	4" 100 mm	73	2651 4110 5102
I3909E-1		TATA 407 TURBO N/M (MSL TYPE)	DCM 30.20X92 4153P	8.20	6	13No.	4" 100 mm	70	
I3909E		TATA 407 TURBO N/M (MSL TYPE)	DCM 30.20X92 4153P	8.20	6	13No.	4.72" 120 mm	70	
I3909D		TATA 407 TURBO EX 410 /709/909	CANTER 30.20X106 4131P	10.20	6	17No.	4.72" 120 mm	87	SDFY1410D120 3-2-0058 2641 4111 5101
I3909DP		CANTER SERATED	CANTER 30.20X106 4131P	11.00	4	18No.	4.72" 120 mm	82	
I3909F		TATA 407 PICK UP	35X106 4050-1	10.2	6	17No.	4.72" 120 mm	88	

MOD[®] PLUS

TATA











**FLANGE YOKE /
CROSS HOLDER**

Part No.	Products	Application	UJ Cross Cross Ref.	Hole Size	No. of Holes	Bolt Size	Plate Size	Height MM	O.E.M Ref.
I5340B		RSB 325 SERIES TATA 2515 EX 1613LP, 1616	RSB 325 42X120 4054AP 4054AP2	10.20	8	17No.	5" 130 mm	114	2632 4110 5105
I5377B		TATA 2516,3518 C EX, 2518 LPT	RSB 325 42X120 4054AP2	12.10	8	19No.	6" 150 mm	107	
I5313A-5		TATA 2515 EX HT.110MM (SERATED)	RSB 325 42X120 4054AP2	10.20	4	17No.	5" 130 mm	107	
I5313A-7		TATA 2515 EX TATA 1616,1613 EURO-III (SERATED)	RSB 325 42X120 4054AP2	13.00	4	19No.	6" 150 mm	110	
I5313A-8		LPK 2516 MTR LPO 1614, 1616 LONG HEIGHT (SERATED)	RSB 325 42X120 4054AP2	13.00	4	19No.	6" 150 mm	128	
I5340C		RSB 403 SERIES TATA 2516 LPK BIG	RSB 42X129 4054BP2	16.20	8	24No.	6.5" 165 mm	133	VDFY0403H135 10025032
I5313A		RSB-403 SERIES TATA LPT 1613 LPK-2516,1616 (SERATED)	RSB 42X129 4054BP2	13.00	4	19No.	6" 150 mm	110	
I5313A-1		RSB 403 SERIES LPK 2516 INTERAXLE LONG HEIGHT (SERATED)	RSB 42X129 4054BP2	13.00	4	19No.	6" 150 mm	128	
I5313A-3		TATA 3118/1618/ 2518 2521/AMW 2518 L/L 2516/4921 3121/MAN-25 T (SERATED)	4018(PT) 49.2X154.5 4054DP	13.00	4	19No.	6" 150 mm	113	SDFY1710D150T 6-2-15 2846 4112 5101
I5313A-4		TATA 1623/1625/1628 HT.120MM (SERATED)	4018(PT) 49.2X154.5 4054DP	15.00	4	22No.	7" 180 mm	120	SDFY1710D180T 6-2-25 27900 0142

MOD[®] PLUS

TATA



**FLANGE YOKE /
CROSS HOLDER**

Part No.	Products	Application	UJ Cross Cross Ref.	Hole Size	No. of Holes	Bolt Size	Plate Size	Height MM	O.E.M Ref.
I5377C		TATA 2518 LPK	1312 46MM 4054P	12.10	8	17No.	6" 150 mm	124	
I5840		EICHER 40.40, TERRA 25, AMW 2530,2528,4018	4018 (PT) 49.2X154.8 4054DP	12.00	12	19No.	8" 200 mm	109	6-2-1279
I5362A		TATA 4018, PATTI TYPE	4018 (PT) 49.2X154.8 4054DP	16.20	8	24No.	6.5" 165 mm	134	SDFY1710D165 6-2-1259
I5723		TATA 4018,4022 3516 N/M (LOCK TYPE)	RSB 490 48X135 4054CP	16.20	8	24No.	6.5" 165 mm	125	
I5719		RSB 490 TATA 4018 HEIGHT 4.5" HT.115 (SERATED)	RSB 490 48X135 4054CP	13.00	4	19No.	6.5" 150 mm	119	
I5313A-2		RSB 490 SERIES TATA 4018 HEIGHT 5.25" HT.135MM (SERATED)	RSB 490 48X135 4054CP	13.00	4	19No.	6.5" 165 mm	135	
I5313A-6		RSB 490 SERIES TATA 4018 L/L 4921,HT.110 (SERATED)	RSB 490 48X135 4054CP	15.00	4	22No.	7" 180 mm	112	
I5723A		RSB 490 SERIES TATA 4018 L/L 4921,HT.130 (SERATED)	RSB 490 48X135 4054CP	15.00	8	22No.	7" 180 mm	126	
I5718J		TATA LPS 4928,3138 LPK 2528, L/L3119N BHARAT BENZ 2523C, 2528C 3128C 4928TT (SERATED)	SPR-2040 47.68X135.10 4054EP	13.00	4	19No.	6" 150 mm	134	66874070 80204 0261
I5930A-1		TATA LPS 4028 LPK 3128, L/L 3123 BHARAT BENZ 2523C, 4023TT EICHER TERRA 25T MAN CLA 18.28	52X147 4122A	13.00	4	19No.	6" 150 mm	140	6687757 080203 0273

MOD[®] PLUS

TATA

**FLANGE YOKE /
CROSS HOLDER**

Part No.	Products	Application	UJ Cross Cross Ref.	Hole Size	No. of Holes	Bolt Size	Plate Size	Height MM	O.E.M Ref.
I5930A		TATA 2523 TC 3118 LPK (SERATED)	52X147 4122A	14.00	4	22No.	7" 180 mm	124	
N/A		TATA LPTA 1828 LPO 2138, L/L HMW 6X6 SHA-8T MERITOR AXLE, EICHER TIPPER 25T 250HP, MAN LPTA 1828 6X6 (SERATED)	52X133 SPR 2047 4122	15.00	4	22No.	7" 180 mm	130	6687457 080207 0273
I6200		TATA LPTA-1628 2038-L/L 4936 BHARAT BENZ LTPA-1628 LTPA-2038 (SERATED)	57X152 4113A	15.00	4	22No.	7" 180 mm	130	6687557 080200 0294
N/A		TATA LPK 3138 L/L-FV-2636 EICHER 40T TIPPER MAN 31.28 (SERATED)	59X167.7 SPR 2060	15.00	4	22No.	7" 180 mm	143	6687607 080200 0310

MOD[®] PLUS

LEYLAND

FLANGE YOKE / CROSS HOLDER

Part No.	Products	Application	UJ Cross Cross Ref.	Hole Size	No. of Holes	Bolt Size	Plate Size	Height MM	O.E.M Ref.
I5313		L/L 2214, 3516/ 2516/1616/TC AC/ EICHER 30.25	L/L 2214 41.28X126 4104GP	9.50	8		7"	116	90-2-19
							175 mm		
I4850		L/L 350/370 BEDFORD	L/L-370 39.67 X 115.4 4090P	12.80	4		6"	95	K4-2GB 231
							146 mm		
I4958		L/L TUSKER EICHER JUMBO 20.16, TERRA-16 EICHER 11.10 XP	TUSKER 34.92 X 126 4104P	12.80	4		SQR	80	F2133311
I5129		L/L TAURUS	LEYLAND 47.62 X 135 4104EP	9.50	8		7"	110	MSL 3502027
							175 mm		
I5343		RSB-403 L/L 2516/3516	RSB403 42 X 129 4054BP2	9.50	8		7"	136	VDFY0403D175 10025072
							175 mm		
I5313B2		L/L IVECO SERATED	TUSKER 34.92 X 126 4104P	11.00	4		5"	91	
							120 mm		











EICHER

I4044		CANTER N/M	CANTER N/M 30.20X106 4131P	8.0	4		7"	75	
							180 mm		

MOD[®] PLUS

TATA











COUPLING FLANGE

Part No.	Products	Application	No. of Splines	No. of Holes	Hole Size	Bolt Size	Plate Size	Type Height	O.E.M Ref.
13522		CENTRE COUP. TATA 1210	14	6	10.20	17No.	5"	ROUND	
							120 mm	62 mm	
13531		GEAR COUP. TATA 1210	14	6	10.20	17No.	5"	ROUND	
							120 mm	62 mm	
13536		DIFF. COUP. TATA 1210	26	6	10.20	17No.	5"	ROUND	
							120 mm	61 mm	
13608		GEAR COUP. GBS-40	16	6	10.20	17No.	5"	ROUND	
							120 mm	63 mm	
14021		TATA-410/909 MARCOPOLO	16	6	10.20	17No.	5"	ROUND	
							120 mm	63 mm	
13810		CENTRE COUP. TATA 1312	14	8	10.20	17No.	5"	ROUND	2575 4110 0104
							130 mm	64 mm	
13815		GEAR COUP. TATA 1312	16	8	10.20	17No.	5"	ROUND	2507 2620 5001
							130 mm	70 mm	
N/A		GEAR COUP. TATA 909 HT 61MM	16	8	10.20	17No.	5"	ROUND	
							130 mm	61 mm	
13819		DIFF. COUP. TATA 1312	26	8	10.20	17No.	5"	ROUND	2676 3520 0110
							130 mm	61 mm	
13824		CENTRE COUP. TATA 2416	26	8	10.20	17No.	5"	ROUND	2632 4111 0111
							130 mm	76 mm	

MOD[®] PLUS

TATA

COUPLING FLANGE

Part No.	Products	Application	No. of Splines	No. of Holes	Hole Size	Bolt Size	Plate Size	Type Height	O.E.M Ref.
I3824A		CENTRE COUP. 2416 N/M TATA 2515 HEIGHT 4"	26	8	10.20	17No.	5"	ROUND	INSUK 100847
							130 mm	92 mm	
I5377E		DIFF. COUP. TATA 2518	26	8	12.10	19No.	6"	ROUND	
							150 mm	63 mm	
I5377EP		CENTRE / DIFF. FLANGE BIG TATA 2518 HT.82MM	26	8	12.80	19No.	6"	ROUND	
							150 mm	80 mm	
I5371		CENTRE COUP. CONVT. TATA 2515/3516	34	8	10.20	17No.	5"	ROUND	
							130 mm	77 mm	
I5371A		CENTRE COUP TATA 1616 / 1613	34	8	10.20	17No.	5"	ROUND	
							130 mm	77 mm	
I5377F		CENTRE COUP. TATA 2518	34	8	12.10	19No.	6"	ROUND	INSUK 100851
							150 mm	78 mm	
I5360A		CENTRE COUP. TATA 2516 TC	34	4	12.80	21No.		ROUND	
							SQR	78 mm	
I5373C		GEAR COUP. GB 60	18	8	10.20	17No.	5"	ROUND	
							130 mm	90 mm	
I5377D		GEAR COUP. TATA 4018	18	8	12.10	19No.	6"	ROUND	
							150 mm	63 mm	
I5373		DIFF. COUP. CONVT. TATA 2515/3516	41	8	10.20	17No.	5"	ROUND	
							130 mm	93 mm	

MOD[®] PLUS

TATA











COUPLING FLANGE

Part No.	Products	Application	No. of Splines	No. of Holes	Hole Size	Bolt Size	Plate Size	Type Height	O.E.M Ref.
I5372		DIFF. COUP. CONVT. TATA 2515/3516 (Oil Seal 71MM)	39	8	10.20	17No.	5"	ROUND	
							130 mm	87 mm	
N/A		DIFF. COUP. CONVT. TATA 3516/2516 (Oil Seal 76MM)	39	8	10.20	17No.	5"	ROUND	
							130 mm	93 mm	
I4535B		DIFF. COUP. 2518 N/M	39	4	12.80	19No.	6"	ROUND	
							150 mm	86 mm	
I5361A		DIFF. COUP. 2516 TC	39	4	12.80	21No.		SQR	
								87 mm	
I5373B		DIFF. COUP. TATA 2515, 3516 SPICER TYPE CROSS TUSKER, PATTI TYPE	39	4				PATTI TYPE	INSKU 100476
								120 mm	
I5373A		DIFF. COUP. TATA 2515, 3516 SPICER TYPE CROSS SPL 90, 41.28 PATTI TYPE	41	4				PATTI TYPE	INSKU 100475
								118 mm	
I5362H		DIFF. COUP. TATA 2516 TC	41	4	1280	21No.		SQR	
								87 mm	
I4512		CENTRE COUP. 1510 TC	10	4		17No.		PATTI TYPE	2632 4111 5104
I4508		CENTRE COUP. 1510 TC	16	4		13No.		PATTI TYPE	2505 2620 5101
I4503		DIFF. COUP. 1510 TC SPICER TYPE	26	4		13No.		PATTI TYPE	2575 3530 0120
								113 mm	

MOD[®] PLUS

TATA











COUPLING FLANGE

Part No.	Products	Application	No. of Splines	No. of Holes	Hole Size	Bolt Size	Plate Size	Type Height	O.E.M Ref.
I3936		CENTRE COUP. TATA 407	16	6	8.20	13No.	4"	ROUND	2651 4110 0122
							100 mm	57 mm	
I3940		GEAR COUP. TATA 407	16	6	8.20	13No.	4"	ROUND	2515 2620 0111
							100 mm	57 mm	
I3941		DIFF. COUP. TATA 407	16	6	8.20	13No.	4"	ROUND	2664 3335 0101
							100 mm	57 mm	
I3936A		CENTRE COUP. CONV. 407/1210	16	6	10.20	17No.	4.72"	ROUND	
							120 mm	54 mm	
I3940A		GEAR COUP. CONV. 407/1210	16	6	10.20	17No.	4.72"	ROUND	
							120 mm	54 mm	
I3945		DIFF COUP. CONV 407/1210	16	6	10.20	17No.	4.72"	ROUND	
							120 mm	54 mm	
I5362D		GEAR COUP. TATA 4018	18	8	16.20	24No.	6.5"	ROUND	
							165 mm	76 mm	
I5362E		DIFF. COUP. TATA 4018	41	8	16.20	24No.	6.5"	ROUND	
							165 mm	92 mm	
I5362E-1		DIFF. COUP. TATA 4018 N/M	26	8	16.20	24No.	6.5"	ROUND	
							165 mm	76 mm	
I5362E-2		DIFF. COUP. TATA 4018 HT 110MM	39	8	16.20	19No.	6.5"	ROUND	
							165 mm	109 mm	

MOD[®] PLUS

TATA











COUPLING FLANGE

Part No.	Products	Application	No. of Splines	No. of Holes	Hole Size	Bolt Size	Plate Size	Type Height	O.E.M Ref.
I53I3C		GEAR COUP. TATA 2518 HEIGHT 63MM (SERATED)	18	4	13.00	19No.	6"	SERATED	
							150 mm	61 mm	
I53I3D		CENTRE / DIFF. FLANGE SMALL TATA 2518 HT.63MM (SERATED)	26	4	13.00	19No.	6"	SERATED	90-I-0017
							150 mm	61 mm	
I53I3D-1		TATA 3128 L/L FV 3136 LPK-2518 TC BORE-68MM (OIL SEAL-90MM) (SERATED)	26	4	13.00	19No.	6"	SERATED	581035 300010
							150 mm	85 mm	
I53I3D-2		DIFF. FLANGE TATA 2518 DIAMOND CUT HEIGHT 63MM SMALL (SERATED)	26	4	13.00	19No.	6"	SERATED	
							150 mm	61 mm	
I5723D		CENTRE / DIFF. FLANGE BIG TATA 2518 HT.82MM (SERATED)	26	4	13.00	19No.	6"	SERATED	
							150 mm	80 mm	
I5724		CENTRE COUP. TATA 2518 HT 95MM (SERATED)	26	4	13.00	19No.	6"	SERATED	
							150 mm	96 mm	
I5723B		GEAR COUP. TATA GBS 75 2518 / 4018 HT. 110MM (SERATED)	26	4	13.00	19No.	6"	SERATED	
							150 mm	109 mm	
I5723C		CENTRE COUP. TATA 3118 (SERATED)	16	4	13.00	19No.	6"	SERATED	
							150 mm	80 mm	
I53I3F-1		PINION COUP FLANGE TATA 2518/4018 HT.95MM OIL SEAL 70MM (SERATED)	39	4	13.00	19No.	6"	SERATED	
							150 mm	93 mm	
I53I3F		PINION COUP FLANGE TATA 2518/4018 HT.95MM OIL SEAL 76MM (SERATED)	39	4	13.00	19No.	6"	SERATED	
							150 mm	93 mm	

MOD[®] PLUS

TATA









COUPLING FLANGE

Part No.	Products	Application	No. of Splines	No. of Holes	Hole Size	Bolt Size	Plate Size	Type Height	O.E.M Ref.
I5313G		PINION COUP TATA 2518/4018 (OIL SEAL 71MM) HT.95MM (SERATED)	41	4	13.00	19No.	6"	SERATED	
							150 mm	93 mm	
I5313G-1		PINION COUP TATA 2518/4018 (OIL SEAL 76MM) HT.95MM (SERATED)	41	4	13.00	19No.	6"	SERATED	
							150 mm	93 mm	
I5313K		TATA LPK 3118 TATA LPK 2523 3718,3723 (SERATED)	30	4	14.00	22No.	7"	SERATED	
							180 mm	117.5 mm	
I5313-I		TATA 3118 LPT/2518/ 3718/3119AL DIAMOND CUT (SERATED)	20	4	13.00	19No.	6"	SERATED	
							150 mm	70 mm	
I5313J		TATA 3118 LPT/ 2518/MNAL 63MM OIL SEAL (SERATED)	20	4	13.00	19No.	6"	SERATED	
							150 mm	74 mm	
I5750F		TATA LPT 3127, 2527, LPK 3128, L/L FVDP 3123, 2523/CLA31.28 (SERATED)	20	4	13.00	19No.	7"	SERATED	
							180 mm	71 mm	
I5840A		THRU SHAFT L/L 3118,3123 EICHER 40.40	32	12	12.80	19No.	8"	ROUND	
							205 mm	72 mm	
I5840B		GEAR FLANGE L/L 3118,3123 EICHER 40.40	31	12	12.80	19No.	8"	ROUND	
							205 mm	81 mm	
I5840C		THRU SHAFT L/L 3118,3123	39	12	12.80	19No.	8"	ROUND	
							205 mm	85 mm	
I5840D		AMW,EICHER 40.40 TERRA 25	46	12	12.80	19No.	8"	ROUND	
							205 mm	85 mm	

MOD[®] PLUS

EICHER











COUPLING FLANGE

Part No.	Products	Application	No. of Splines	No. of Holes	Hole Size	Bolt Size	Plate Size	Type Height	O.E.M Ref.
I4062		CENTRE COUPL. EICHER N/M	10	4	12.10	19No.		SQR	
I4080		PINION COUPL. EICHER N/M	14	4	12.10	19No.		SQR 61 mm	
I4018B		PINION COUPL. EICHER 10.90	14	4	12.10	19No.	125 mm	ROUND 72 mm	
I4019		PINION COUPL. EICHER 11.10	18	4	12.10	19No.	125 mm	ROUND 66 mm	
I4096		EICHER 11.10	16	4	12.10	19No.		SQR 96 mm	
I4096A		EICHER TERRA 16	34	4	12.10	19No.	6" 150 mm	SQR 75 mm	
I4096B		EICHER TERRA	34	4		19No.	6"	SERATED 73 mm	
I4085		GEAR COUPL. EICHER CANTRE	18	4	12.10	19No.			

MOD[®] PLUS

LEYLAND







COUPLING FLANGE

Part No.	Products	Application	No. of Splines	No. of Holes	Hole Size	Bolt Size	Plate Size	Type Height	O.E.M Ref.
I4895A		GEAR COUP. L/L 350/370 TUSKER	6	4	12.80	21No.		SQR 100 mm	
I4895		GEAR COUP. L/L 350/370 TUSKER	6	4	12.80	21No.	6" 146 mm	ROUND 97 mm	F1431022
I4881		PINION COUP. L/L 350/370 TUSKER	10	4	12.80	21No.	6" 146 mm	ROUND 85 mm	F1432611
I5012		CENTRE COUP. L/L TUSKER	10	4	12.80	21No.		SQR 75 mm	F1430211
I4535A		CENTRE COUP. L/L 1613 TURBO	10	4	12.80	21No.	6" 150 mm	ROUND 63 mm	4-I-5401
I5160A		CENTRE COUP. L/L TAURUS 1616	10	8	9.50	15No.	7" 175 mm	ROUND 92 mm	F1433311
I5160		CENTRE COUP. L/L TUSKER 1616	16	8	9.50	15No.	7" 175 mm	ROUND 92 mm	F1433311
I5360B		GEAR COUP. L/L 2214, TAURAS	28	8	9.50	15No.	7" 175 mm	ROUND 62 mm	F14351711
I5360C		GEAR COUP. Z/F TYPE L/L ZF (BELL TYPE)	28	8	9.50	15No.	7" 175 mm	ROUND 115 mm	
I5360D		GEAR COUP. L/L-1616, CARGO INTERAXLE ZF SQUIRE TYPE	28	4	12.80	21No.		SQR 116 mm	

MOD[®] PLUS

LEYLAND





COUPLING FLANGE

Part No.	Products	Application	No. of Splines	No. of Holes	Hole Size	Bolt Size	Plate Size	Type Height	O.E.M Ref.
I536I		DIFF. COUP. L/L 2214 TAURUS (OIL SEAL 76.20MM)	39	8	9.50	15No.	7"	ROUND	P4300214
							175 mm	91 mm	
I536IC		DIFF. COUP. L/L 2214 TAURUS (OIL SEAL 71.30MM)	39	8	9.50	15No.	7"	ROUND	
							175 mm	89 mm	
I536ID		DIFF. COUPLING L/L 2516 HT 102MM	39	4	12.80	21No.	6"	ROUND	
							150 mm	104 mm	
I5362		DIFF COUP. L/L 2214	41	8	9.50	15No.	7"	ROUND	
							175 mm	91 mm	
I5360		CENTRE COUP. L/L 2214	34	8	9.50	15No.	7"	ROUND	5-1-6501
							175 mm	61 mm	
I5313E-1		CENTRE COUP. L/L-3116,2516,2515 EICHER-35.31 HEIGHT-63MM (SERATED)	34	4	13.00	19No.	6"	SERATED	19-1-15
							150 mm	61 mm	
I5313E-2		CENTRE COUP. TATA 2515/2518 THRU SHAFT HEIGHT-85MM (SERATED)	34	4	13.00	19No.	6"	SERATED	
							150 mm	84 mm	
I5313E		GEAR COUP. FLANGE L/L ZF HT.100MM	28	4	13.00	19No.	6"	SERATED	
							150 mm	100 mm	
N/A		GEAR COUP. EATON-TATA, AL BHARAT BENZ	28	4	13.00	19No.	6"	ROUND	330106
							150 mm	75 mm	
N/A		GEAR COUPLING (SERATED)	28	4	15.00	22No.	7"	ROUND	
							180 mm	87 mm	

MOD[®] PLUS

LEYLAND

COUPLING FLANGE

Part No.	Products	Application	No. of Splines	No. of Holes	Hole Size	Bolt Size	Plate Size	Type Height	O.E.M Ref.
I5313H		INPUT SHAFT L/L-2518	44	4	13.00	19No.	6"	SERATED	
							150 mm	91 mm	
I5750		DIFF. COUP. TATA 4018,2518 L/L 4923,4921 OIL SEAL 76MM (SERATED)	39	4	15.00	22No.	7"	SERATED	
							180 mm	111 mm	
I5750C		DIFF. COUP. TATA 4018,2518 L/L 4923,4921 OIL SEAL 71MM (SERATED)	39	4	15.00	22No.	7"	SERATED	
							180 mm	111 mm	
I5750A		DIFF. COUP. TATA 4018, L/L 2518 (SERATED)	44	4	15.00	22No.	7"	SERATED	
							180 mm	110 mm	
I5750B		DIFF. COUP. TATA 4018, L/L 2518 (SERATED)	41	4	15.00	22No.	7"	SERATED	
							180 mm	111 mm	
I5750E		DIFF. COUP. TATA 4018, L/L 2518 (SERATED)	46	4	15.00	22No.	7"	SERATED	
							180 mm		
I5750D		CENTRE COUP. TATA 4018, L/L 2518 (SERATED)	31	4	15.00	22No.	7"	SERATED	19-1-15
							180 mm	70 mm	
N/A		GEAR COUP TATA 4018, L/L 2518 (SERATED)	21	4	15.300	22No.	7"	SERATED	
							180 mm		
N/A		GEAR COUP. GB-75 TATA 4018, L/L 2518 (SERATED)	26	4	15.00	22No.	7"	SERATED	
							180 mm	106 mm	
I5361-E		DIFF. COUP. L/L-2516	26	8	9.50	15No.	7"	ROUND	
							175 mm	93 mm	

MOD[®] PLUS

MAHINDRA

YOKE & TEETH SET

Part No.	Products	Application	UJ Cross	Cross Ref.	No. of Splines	Pipe Dia	Mating Housing	O.E.M Ref.
5008D		YOKE & TEETH SCORPIO (COATED)	JEEP 27X81.80	4009P	16	60MM		3220458 3220478
5008F		YOKE & TEETH BOLERO-6" (COATED)	JEEP 27X81.80	4009P	16	60MM		3220455 3220475
5008E		YOKE & TEETH UTILITY-7" (COATED)	JEEP 27X81.80	4009P	16	60MM		3220452 3220472
5008C		YOKE & TEETH MAX PICK UP	JEEP 27X81.80	4009P	16	71MM		3220462 3220492
5008G		YOKE & TEETH MAX PICK UP (COATED)	JEEP 27X81.80	4009P	16	71MM		3220462 3220492
5008I		YOKE & TEETH MAXI TRUCK	JEEP 27X81.80	4009P	16	66MM		3220457 3220477
5008H		YOKE & TEETH MAXI TRUCK (COATED)	JEEP 27X81.80	4009P	16	66MM		3220457 3220477
5008J		YOKE & TEETH MAHINDRA JEEP BOLERO DI SLX (COATED)	JEEP 27X81.80	4009P	16	60MM		3220431 3220432
5008K		YOKE & TEETH MAHINDRA JEEP THAR (COATED)	JEEP 27X81.80	4009P	16			
5013A		YOKE & TEETH MAHINDRA XYLO BOLERO DI SLX (COATED)	JEEP 27X81.80	4009P	16	59.55 MM		3220469

MOD[®] PLUS

MAHINDRA JEEP/BOLERO/MAXX PICKUP/MAXI TRUCK (CROSS SIZE-27X81.80)

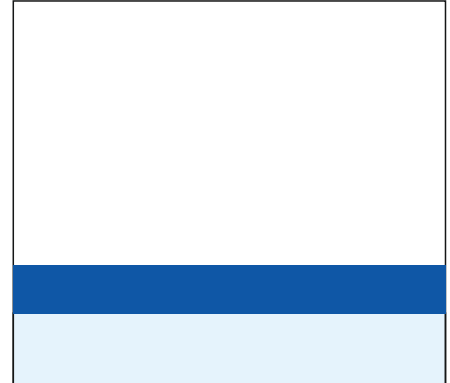

PRO. SHAFT HALF YOKE MAHINDRA (CROSS SIZE-27X81.80)



PRO. SHAFT COUPLING FLANGE MAHINDRA



PRO. SHAFT COUPLING FLANGE SUMO/207 DI/ SPICER PATTI TYPE

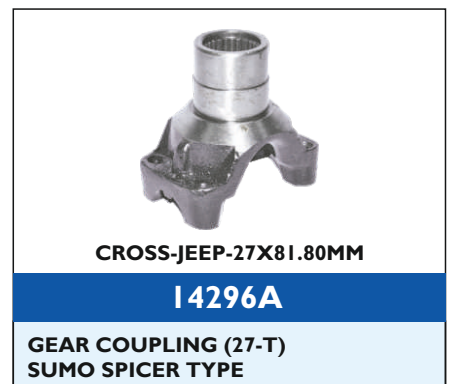
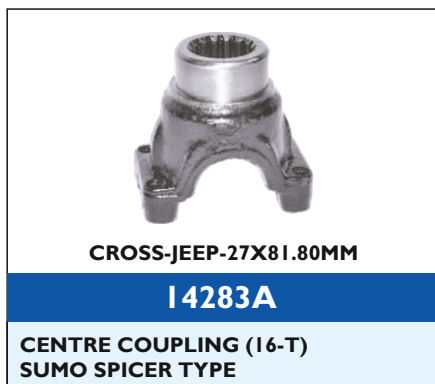

MOD[®] PLUS

PRO. SHAFT TATA ACE, MAHINDRA MAXIMO, L/L-DOST

 <p>CROSS-23.82X35.25 15570 CROSS HOLDER TATA ACE O/M (INNER LOCK)</p>	 <p>CROSS-23.82X35.25 15552 HALF YOKE TATA ACE O/M (INNER LOCK)</p>	 <p>CROSS-23.82X35.25 15561 SLIDING YOKE (22-T) 6.25" TATA ACE O/M (INNER LOCK)</p>	 <p>15624A PINION COUPLING TATA ACE O/M (23-T)</p>
 <p>CROSS-22.00X55.00 15597 CROSS HOLDER TATA MAGIC N/M (OL)</p>	 <p>CROSS-22.00X55.00 15606 HALF YOKE TATA MAGIC N/M (OL)</p>	 <p>CROSS-22.00X55.00 15624 SLIDING YOKE (22-T) 5.75" TATA MAGIC N/M (OL)</p>	 <p>15624B PINION COUPLING TATA MAGIC N/M (23-T)</p>
 <p>CROSS-27X81.80 15390 CROSS HOLDER TATA ACE SUPER</p>	 <p>CROSS-27X81.80 15408 HALF YOKE TATA ACE SUPER</p>	 <p>CROSS-27X81.80 15399 SLIDING YOKE TATA ACE SUPER</p>	 <p>15417 PINION COUPLING TATA ACE SUPER (26-T)</p>
 <p>CROSS-27X81.80 15421 CROSS HOLDER LEYLAND DOST</p>	 <p>CROSS-27X81.80 15430 HALF YOKE LEYLAND DOST</p>	 <p>CROSS-27X81.80 15426 SLIDING YOKE LEYLAND DOST</p>	 <p>15435 PINION COUPLING LEYLAND DOST</p>
 <p>CROSS-27X81.80 5098A CROSS HOLDER MAHINDRA MAXIMO</p>	 <p>CROSS-27X81.80 5098C HALF YOKE MAHINDRA MAXIMO</p>	 <p>CROSS-27X81.80 5098B SLIDING YOKE MAHINDRA MAXIMO</p>	 <p>5098D PINION COUPLING MAHINDRA MAXIMO (26-T)</p>

MOD[®] PLUS

STEERING CROSS ASSEMBLY

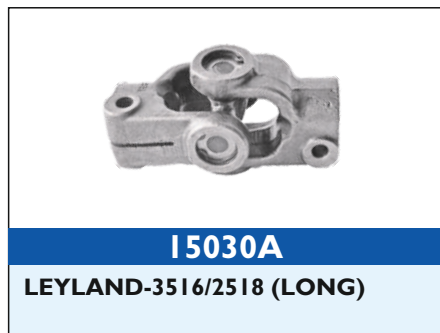
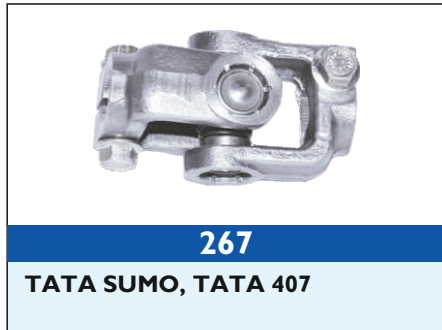

MOD[®] PLUS

STEERING CROSS ASSEMBLY



I5588C

TATA ACE WITH ROD O/M-15.5"



I5590

TATA ACE WITH ROD MAGIC-16"



I5589

TATA ACE, IRIS-18"



I5589A

TATA ACE, IRIS BIG HOLE-18"



I5590A

TATA IRIS WITH ROD (SMALL-5")



I5590B

TATA IRIS WITH ROD (SMALL-5") WITH BIG HOLE



I5588C-1

TATA ACE SUPER WITH ROD-20"



I5435A

LEYLAND DOST WITH ROD POWER STEERING



I5435C

LEYLAND DOST UPPER



I5588-D

STG. SECTOR SHAFT
TATA ACE



I5588A

STG WORMS - TATA ACE



I5588B

TATA ACE N/M MAGIC



I5588B-1

TATA ACE-N/M (FORNI MAKE)
RANE TYPE



I5580

TATA ACE LATEST, SUPER ACE



I5580A

TATA ACE DICOR
LONG ROD

MOD[®] PLUS

STEERING CROSS ASSEMBLY



2412AP

EICHER 10.60/10.70/10.90
(OE. 302364) LENGTH-9.25"

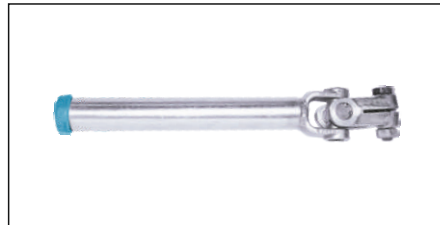

2412BP

EICHER 10.95 (LONG)
LENGTH-10.5"



2412CP

EICHER 11.10
LENGTH-9"

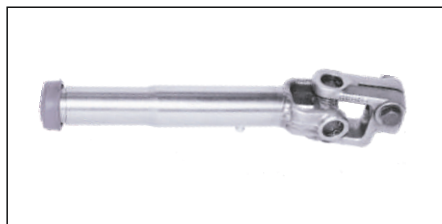

2412DP

EICHER JUMBO
LENGTH-9.6"

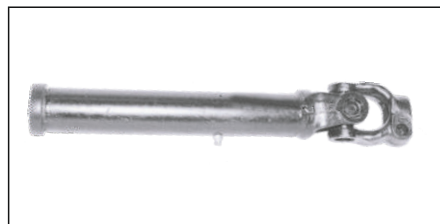

I4913-F

EICHER JUMBO, GALAXY (16-T)
(OE. NO-312380) LENGTH-14"



I4913-G

EICHER JUMBO, GALAXY POWER
STEERING (16-T) LENGTH-14"



2421P

SWARAJ MAZDA

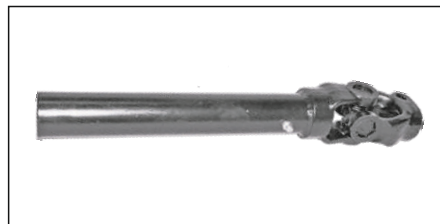

I4913-A

L/L-IVECO 709, STALLION
(OE. NO-F7859500) LENGTH-13"

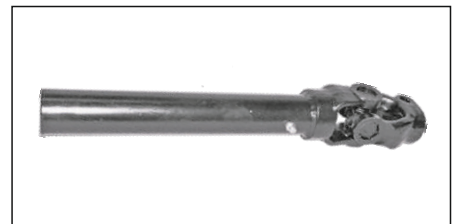

I4913-B

L/L-IVECO-909 N/M
LENGTH-13.5"



I4913-C

LEYLAND U-TRUCK (26-T)
LENGTH-16.25"



I4913-D

LEYLAND U-TRUCK (26-T)
LENGTH-14.25"



I4913-E

LEYLAND U-TRUCK (26-T)
LENGTH-12"



2422

EICHER 10.65,10.85,10.95 N/M
(THICK SPLINE)

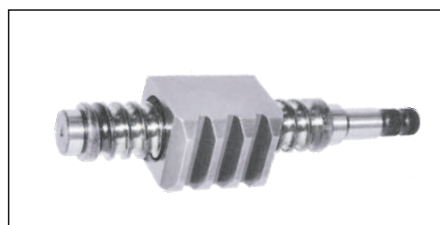

2423

EICEHR 11.10
(THIN SPLINE)



MOD[®] PLUS

STEERING SECTION & WORMS



252

STG. WORM-TATA I210 SE



252-A

**STG. WORM-TATA I613 TC
RANE TYPE (258MM)**



252-B

**STG. WORM-I613/2513 TL
TATA 2515,2416 (BIG)**

256

**STG. SECTOR SHAFT
TATA I210 SE/I312**

252-D

**STG. WORM
TATA I109 (RANE TYPE)**

252-E

**STG. WORM-TATA 709 TURBO
710,712,909,1109 (TATA TYPE)**



15579

**DIFF. SPIDER KIT
TATA ACE**



15579-A

**DIFF. SPIDER KIT
TATA ACE-MAGIC**



15579-B

**DIFF. SPIDER KIT
TATA ACE-VENTURE (34-T)**



5098-E

**STG. CROSS ASSY. WITH ROD
MAHINDRA MAXIMO**







15588



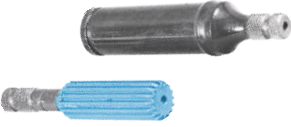
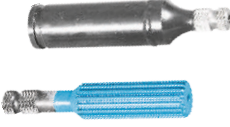
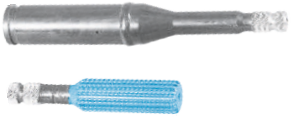

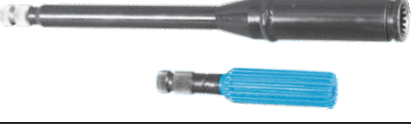
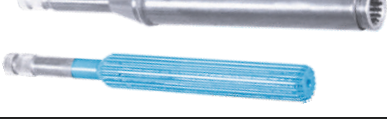
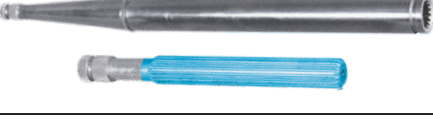
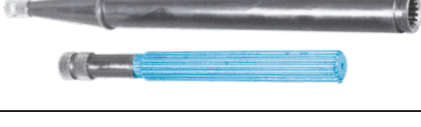
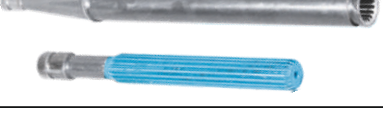

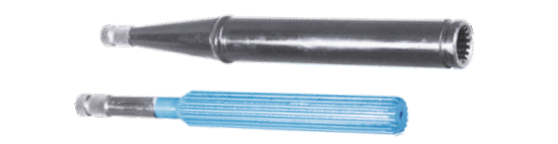
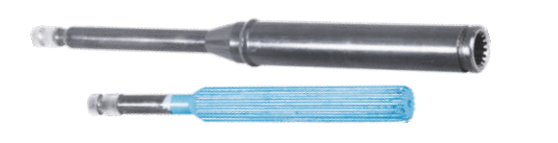

TATA ACE

MOD[®] PLUS

STEERING SPINDLE (YOKE & TEETH)

Part No.	Application	Products	Yoke Length	Teeth Length	Total Length
I5312P	TATA SUMO TOTAL LENGTH-8.5"		6.5"	5.5"	8.5"
I5318P	TATA SUMO DELUX TOTAL LENGTH-8"		6.25"	5.5"	8"
I5323-B	TATA-407 CITYRIDE BUS TOTAL LENGTH-11.5"		9.5"	5.5"	11.5"
I5323-P	TATA-407 TOTAL LENGTH-18"		16"	5.5"	18"
I5323-AP	TATA-407 TURBO TOTAL LENGTH-17.5"		16"	5.5"	17.5"
I5327-P	TATA-609/709 TOTAL LENGTH-16"		14"	5.5"	16"
I5331-P	TATA 709 LPT TOTAL LENGTH-16.5"		13"	11"	16.5"
I5331-AP	TATA-2515 LPT ZF STG. TYPE TOTAL LENGTH-20"		18.25"	11"	20"
I5331-BP	TATA-2515 LPT RANE TYPE TOTAL LENGTH-18.5"		17"	10.5"	18.5"
I5331-CP	TATA-2515 EX 1613 TURBO/SFC TOTAL LENGTH-18"		17"	11"	18"
I5331-DP	TATA-1613 TC TATA 3015 EX TOTAL LENGTH-16.5"		14.5"	11"	16.5"

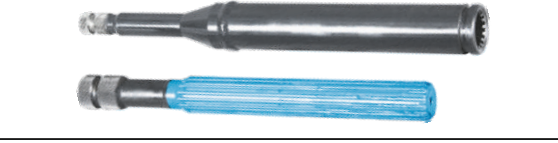
STEERING SPINDLE (YOKE & TEETH)

Part No.	Application	Products	Yoke Length	Teeth Length	Total Length
I5331-E	TATA 1613 LPT		10.25"	8"	11.75"
I5331-FP	TATA-I 109 LPT TOTAL LENGTH-16"		12.75"	11"	16"
I5332	TATA-I 109 EX-N/M TOTAL LENGTH-20"		16.5"	11"	20"
I5333	TATA-909 EX TOTAL LENGTH-18.5"		17"	6"	18.5"
I5334	TATA-207 DI TOTAL LENGTH-15.25"		10"	11"	15.25"
I5334-A	TATA-712 EX TOTAL LENGTH-13.5"		12"	6"	13.5"
I5335	TATA-410 EX TOTAL LENGTH-20"		18"	6"	20"
I5335-A	TATA-3118 1613 BS-III TOTAL LENGTH-15.5"		14"	11"	15.5"
I5335-B	TATA 2518 TATA-4923 TOTAL LENGTH-16.5"		13"	11"	16.5"
I5335-C	TATA-4923 TATA-4018 N/M TOTAL LENGTH-14.25"		13"	8"	14.25"
I5335-D	TATA 4018 EX-O/M		15"	8"	17"

MOD[®] PLUS

CLUTCH FORK



I3558
TATA I210 D



HOLE TO FACE 11" (INNER THREAD)
I3963
TATA 407



HOLE TO HOLE-14"
I3851
TATA GBS-40



HOLE TO HOLE-12.5"
I3863
TATA I312-N/M, I510, I612
GBS-40 SHORT



HOLE TO HOLE-14"
I3863A
TATA I613 TC (LONG)



HOLE TO HOLE-12.5"
I3863A-1
TATA I613 TC (SHORT)



HOLE TO FACE-12.5" (INNER THREAD)
I3860
TATA 709/I109
TATA I312-N/M



HOLE TO FACE-12.5" (INNER THREAD)
I3879
TATA I109 (SINGLE BEND)



HOLE TO FACE-11" (INNER THREAD)
I3879-A
TATA I109 (DOUBLE BEND)



I3863-B
TATA GBS-60



I3863-C
TATA GBS-75



HOLE TO HOLE-17.75"
I3863-D
TATA 3118, 4018
L/L 2516, 3116, 4923

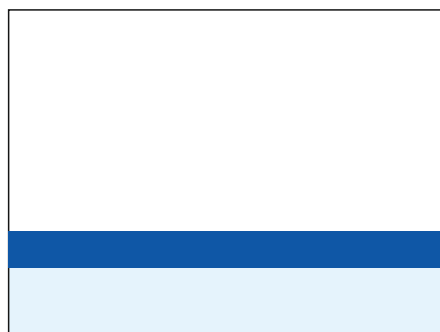

MOD[®] PLUS

GEAR HOUSING BLOCK ASSEMBLY



I5378

TATA I512,1613 TC



I5379

TATA I312 TC



I5380

TATA I313 TC,1613 TURBO



I5381

TATA 2515 TC
L/L-2214,4921



I5382

TATA 2516 TC

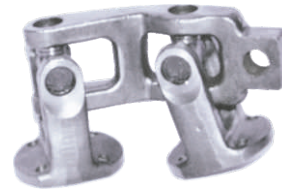

I5383

TATA 1616 TC



I5384

TATA 4018



I5384-A

LEYLAND 3118,3518

MOD[®] PLUS

CLUTCH SECTION (CLUTCH & COVER ASSEMBLY)

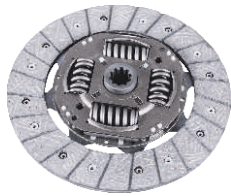

I3909-FP

**MAHINDRA BOLERO,MAX TURBO
(4 SPRINGS) (B-281N)**



I3009-AP

**MAHINDRA BOLERO,MAX TURBO
(0011 LUK TYPE)**

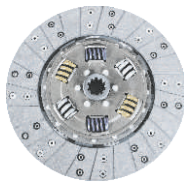

I309-HP

**MAHINDRA MDI TURBO,BOLERO MAXI TRUCK
(6 SPRINGS) (B-285N)**



I3009-FP

**MAHINDRA-MARSHAL/SAVARI/UTILITY/TOURISTER
MDI/MM540/COMMANDER 750/BOLERO**

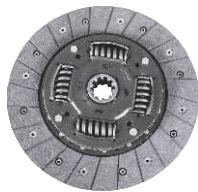

I341-HP

TATA 207 DI TURBO (4 SPRINGS)



I3036-AP

**TATA 407 TURBO,207 DI TURBO
MAHINDRA NISHAN**



I345-BP

FORCE TOOFAN,CRUISER



I3036-P

TATA 407,NEW HOLLAND TRACTOR



I309-GP

**MAHINDRA BOLERO/UTILITY/MARSHAL
(6 SPRINGS) (BA-10)**



I3041-AP

**TATA 609 TURBO/709 TURBO
TRACTOR-INTER 585 DI & ALL FAN TYPE**

Clutch & Cover Assemblies

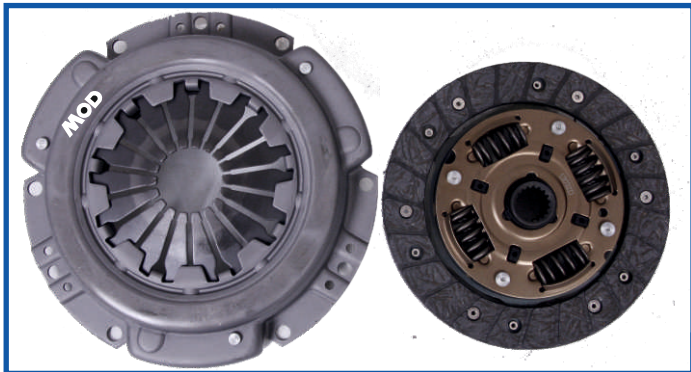

13032D
Clutch Set
TATA ACE

13085BP
Clutch Set
Mahindra Maximo

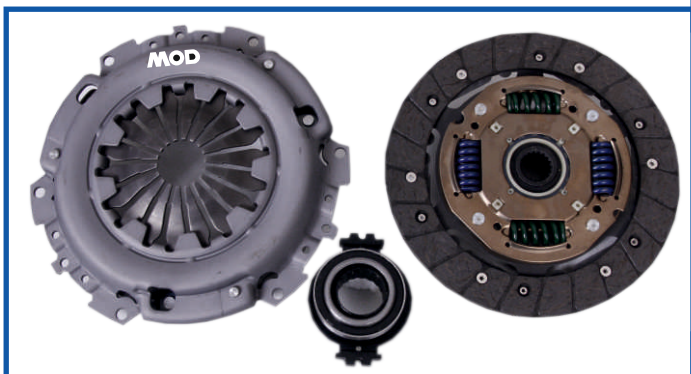
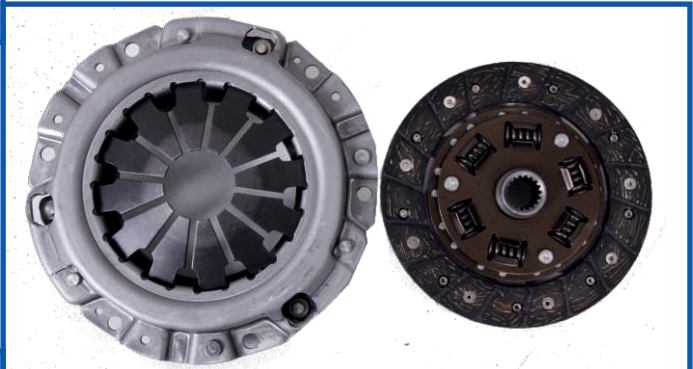

1345C
Clutch Set
Tata Indica



1345CP
Clutch Set TATA TDI
Turbo/Victa/Vista/Indigo

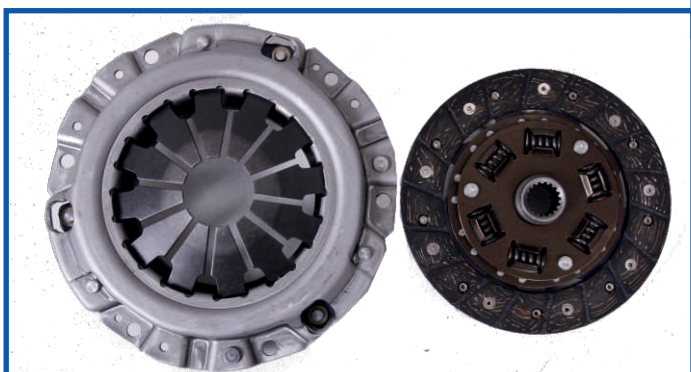

13085AP
Clutch Set
Maruti Car 800

